

*AUTOMOTIVE, AIR CONDITIONING,*



**Mastercool**<sup>®</sup> Inc.  
*"World Class Quality"*

*SERVICE TOOLS AND EQUIPMENT*





**Corporate Office  
Manufacturing and USA Warehouse**

For over 25 years Mastercool has been supplying professional quality air conditioning service tools and equipment. As one of the fastest growing companies in this market, our primary goal is to drive New Product Innovation and Technologies to make the every day work of the technician easier!

With our never-ending focus on innovation and new technology, Mastercool has been awarded many patents worldwide. Our products are currently being distributed in over 55 countries and growing everyday!



**In House Sensor Manufacturing**

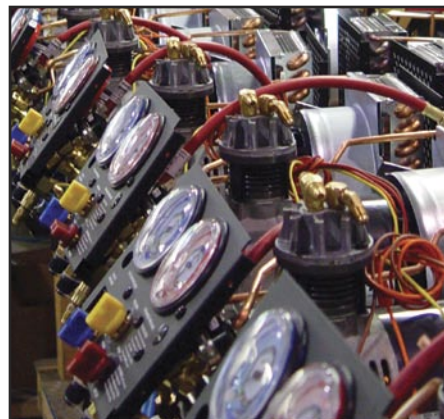

**Recovery Machine Assembly Line**



**Machining Operation**

R134A DIGITAL MANIFOLD.....	4	SPECIALTY HYDRAULIC TOOLS.....	35
ALUMINUM 4-WAY MANIFOLD GAUGE SETS.....	6	TUBING TOOLS.....	37
ALUMINUM 2-WAY MANIFOLD GAUGE SETS.....	7	COMPRESSOR SERVICE TOOLS.....	39
BRASS 2-WAY MANIFOLD GAUGE SETS.....	8	COMPRESSOR TOOL CHART.....	43
MANIFOLD GAUGES & GAUGE PROTECTORS.....	9	INDEX.....	45
CHARGING HOSES.....	10		
AUTOMATIC & MANUAL SHUT-OFF VALVES & HOSES.....	11		
COUPLERS.....	12		
A/C CHARGING ADAPTER REPAIR KITS.....	13		
CHARGING ADAPTERS, REPLACEMENT GASKETS, DEPRESSORS & RETROFIT ADAPTERS.....	14		
RETROFIT ADAPTERS.....	15		
SERVICE TOOLS.....	15		
VALVE CORE REMOVER/INSTALLERS.....	16		
RECOVERY CYLINDERS.....	17		
VACUUM PUMPS.....	18		
CHARGING SCALES & EQUIPMENT.....	20		
RECOVERY & CHARGING EQUIPMENT.....	22		
UV LEAK LOCATOR KITS.....	26		
UV LIGHTS & ACCESSORIES.....	28		
UV DYES & INJECTORS.....	29		
ELECTRONIC LEAK DETECTION.....	30		
INFRARED THERMOMETERS.....	32		
HOSE CRIMPING TOOLS.....	34		



# R134a DIGITAL MANIFOLD

## Mastercool introduces the most advanced and user friendly R134a Digital Manifold on the Market today!

This manifold offers a large easy to read LCD that displays temperature, pressure and vacuum readings for R134a. The unit easily allows the technician to obtain refrigerant and oil capacity readings for 55 automobile manufacturers. This unit also performs systems leak check at the conclusion of the evacuation process. To insure lasting performance and durability the manifold case is constructed of ABS material and protected by a rugged rubber boot.

The technician now has a fully functional manifold with the intelligence to quickly access and deliver the accurate information needed to do the job right!



Heavy-Duty Hook Folds Back Into Unit For Compact Storage

Now Includes: Refrigerants and Oil Capacities for over 1000 Makes and Models

Protective Rubber Boot

Large Easy-To-Read LCD Screen

Keypad Control

Rugged ABS Case

Programming Connector for Software Upgrades

Aluminum Block Manifold With Double O-Ring Free Floating Piston Valves



PATENT PENDING

Patent Pending



CALL 973 252-9119



CLICK [www.mastercool.com](http://www.mastercool.com)

## All the Information you Need, in the PALM OF YOUR HAND!

### DIGITAL LCD DISPLAYS:

REFRIGERANT & OIL CAPACITY  
MANUFACTURER/MODEL/YEAR

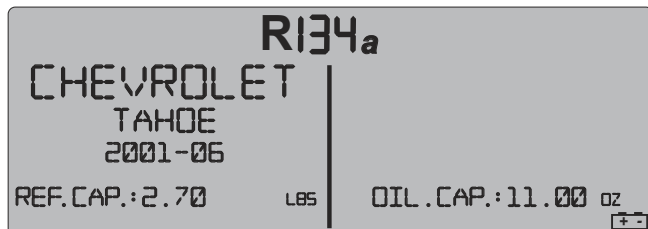

### TEMPERATURE/PRESSURE

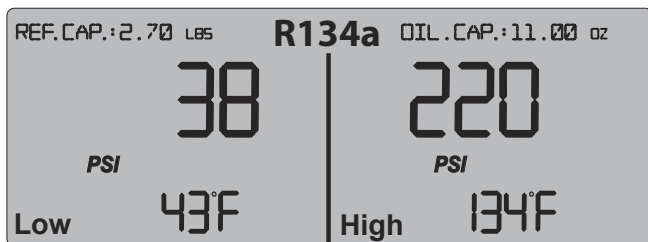

### MANUFACTURERS Included:

Acura	Honda	Mitsubishi	Smart
Alfa Romeo	Hummer	Mercedes-Benz	Subaru
Audi	Hyundai	Nissan	Suzuki
BMW	Infiniti	Oldsmobile	Toyota
Buick	Isuzu	Opel-Vauxhall	Volkswagen
Cadillac	Jaguar	Peugeot	Volvo
Chevrolet	Jeep	Plymouth	
Chrysler	KIA	Pontiac	
Citroen	Lancia	Porsche	
Daewoo	Land Rover	Renault	
Daihatsu	Lexus	Rover	
Dodge	Lincoln	SAAB	
Fiat	Mazda	Saturn	
Ford	Mercury	Scion	
GMC	Mini	Seat	

- 99134-A** Manifold only
- 99860-A** Complete Kit in a blow molded case includes: manifold with a set of 3-60" hoses and a set of manual couplers (82834 & 82934).
- 99872-A** Complete Kit in a blow molded case includes: manifold with a set of 3-72" hoses and a set of manual couplers (82834 & 82934).

**99134-A-UPDT-10** USB Adapter and CD for Software Upgrade

### SPECIFICATIONS

- Refrigerant: R134a
- Pressure & Vacuum Display: Low Side - PSI, Bar, MPa, Kg/cm<sup>2</sup> & IN-Hg  
High Side - PSI, Bar, MPa, Kg/cm<sup>2</sup>
- Temperature Display: -40 to 200°F (-4 to 93°C)
- Response Time: 250 mSec.
- Connection: 1/2" ACME
- Operating Temperature: 32 to 122°F (0 to 45°C)
- Power: 9V DC battery
- Battery Life: 50-60 hours continuous use
- Low Battery Indicator: Special ICON on LCD
- Auto-Off: 15 min. with disabling capability



**Mastercool**<sup>®</sup>  
"World Class Quality"

# ALUMINUM 4-WAY MANIFOLD GAUGE SETS



### 3/8" BORE 4-WAY BALL VALVE MANIFOLD

- Full 3/8" bore through the block increases flow considerably – faster charging & recovery
- Ball valve rotates 90° between two Teflon washers requiring little effort to turn, even under pressure
- Opens and closes quickly with only a quarter turn
- Knob position shows whether valves are open or closed (Vertical = OPEN, Horizontal = CLOSED)

Mastercool is the leading manufacturer of professional quality AC/R manifold gauge sets. Our manifold gauge sets are constructed of the finest materials and machined with precision to the highest standards. At Mastercool, every manifold we build is built to last.

### Mastercool's Aluminum 4-Way Manifolds feature PREMIER SERIES BALL VALVE DESIGN.

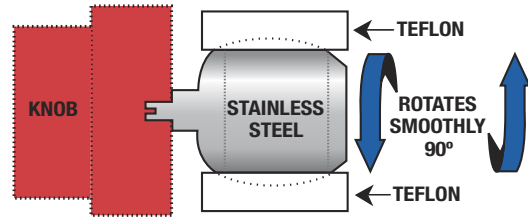

#### Traditional 1/4" Bore

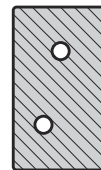

(Side Cut-away View )  
Competitor's Manifold Block  
W/1/4" bore

#### Mastercool's 3/8" Bore

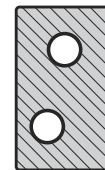

(Side Cut-away View )  
Mastercool's Manifold Block W/3/8" bore  
all the way through the block

**COMPARE!**



**R134a Auto A/C 4-way manifold gauge sets with hoses packaged in blow molded cases. Hose connections for blue and red are 14mm-M. Yellow hose is 1/2" ACME-F with auto shut-off valve. Gauges are 3 1/8" in PSI/Kpa & °F.**

HOSE LENGTH (SET OF 4)	W/O COUPLERS	W/MANUAL COUPLERS	W/E-Z SNAP™ COUPLERS
36"	86536	86936	86436
60"	86561	86961	86461
72"	86572	86972	86472



**R12, R22 and R502 4-way manifold gauge sets with hoses packaged in blow molded cases. Hose connections are 1/4" SAE and gauges are 3 1/8" in PSI & °F.**

HOSE LENGTH (SET OF 4)	STANDARD HOSES STANDARD FITTINGS	STANDARD HOSES AUTO SHUT-OFF VALVES	NYLON BARRIER HOSES STANDARD FITTINGS	NYLON BARRIER HOSES AUTO SHUT-OFF VALVES
36"	95136	95336	95236	95436
60"	95161	95361	95261	95461
72"	95172	95372	95272	95472

To order manifolds with shock-resistant gauge protectors, simply place a "G" after the part number.

### 4-WAY MANIFOLDS W/GAUGES ONLY

- 86103** R134a 3 1/8" (1/2" ACME-M)  
**95103** R12, R22, R502 3 1/8" (1/4" MFL)

### 3 1/8" GAUGES

- 86350** R134a PSI/Kpa & °F Low Side Gauge  
**86500** R134a PSI/Kpa & °F High Side Gauge  
**91250** R12, R22, R502 PSI & °F Low Side Gauge  
**91500** R12, R22, R502 PSI & °F High Side Gauge

### GAUGE PROTECTORS and LENS

- 91253-E** Blue Gauge Protector 3 1/8"  
**91503-E** Red Gauge Protector 3 1/8"  
**91553-E** Set (Red & Blue) Gauge Protectors 3 1/8"  
**98251-E** 3 1/8" Lens

## R134a Auto A/C 2-way manifold gauge sets with hoses packaged in clamshells.

- Hose connections for blue and red are 14mm-M.
- Yellow hose is 1/2" ACME-F with auto shut-off valve.
- Gauges are 2 1/2" in PSI/°F, 3 1/8" in PSI/Kpa & °F.

To order manifolds with shock-resistant gauge protectors, simply place a "-G" after the part no. (2 1/2" only)



HOSE LENGTH (SET OF 3)	W/MANUAL COUPLERS		W/E-Z SNAP™ COUPLERS		W/O COUPLERS	
GAUGE SIZE	2 1/2"	3 1/8"	2 1/2"	3 1/8"	2 1/2"	3 1/8"
36"	89636	89136	88436	88136	85636	85136
60"	89661	89161	88461	88161	85661	85161
72"	89772	89172	88472	88172	85772	85172

## R12, R22 and R502 2-way manifold gauge sets with hoses packaged in clamshells.

- Hose connections are 1/4" SAE.
- Gauges are 2 1/2" or 3 1/8" in PSI & °F.

To order manifolds with shock-resistant gauge protectors, simply place a "-G" after the part no. (2 1/2" only)

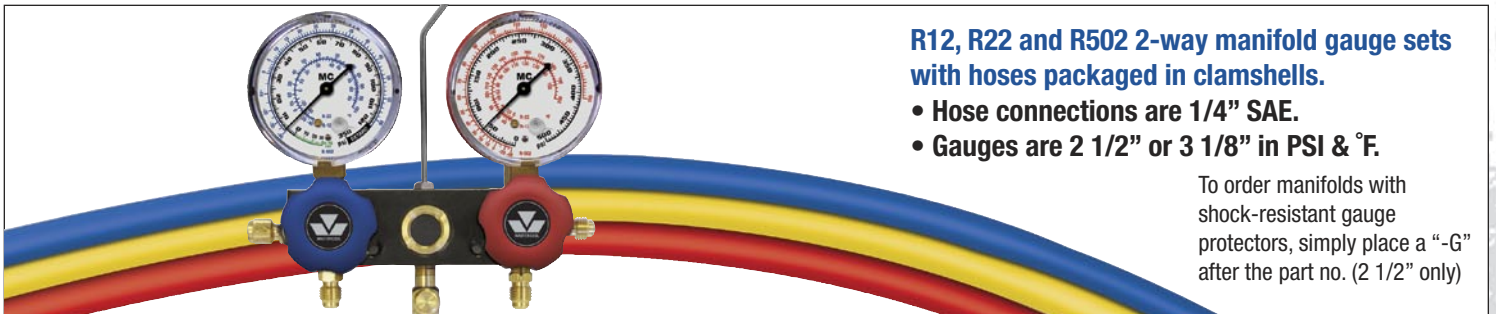

HOSE LENGTH (SET OF 3)	STANDARD HOSES STANDARD FITTINGS		STANDARD HOSES AUTO SHUT-OFF VALVES		NYLON BARRIER HOSES STANDARD FITTINGS		NYLON BARRIER HOSES AUTO SHUT-OFF VALVES		NYLON BARRIER HOSES MANUAL BALL VALVES	
	2 1/2"	3 1/8"	2 1/2"	3 1/8"	2 1/2"	3 1/8"	2 1/2"	3 1/8"	2 1/2"	3 1/8"
GAUGE SIZE	2 1/2"	3 1/8"	2 1/2"	3 1/8"	2 1/2"	3 1/8"	2 1/2"	3 1/8"	2 1/2"	3 1/8"
36"	93636	93136	95636	95536	96636	96136	97636	97136	92636	92136
60"	93661	93161	95661	95561	96661	96161	97661	97161	92661	92161
72"	93772	93172	95772	95572	96772	96172	97772	97172	92772	92172

### 89660 AUTOMOTIVE R134a MANIFOLD GAUGE SET

- Professional Extruded Aluminum Block
- Silicone Dampened, Recalibrateable Gauges
- 3 - SAE Approved Nylon Barrier Hoses
- Professional R134a Couplers
- Custom Molded Carrying Case

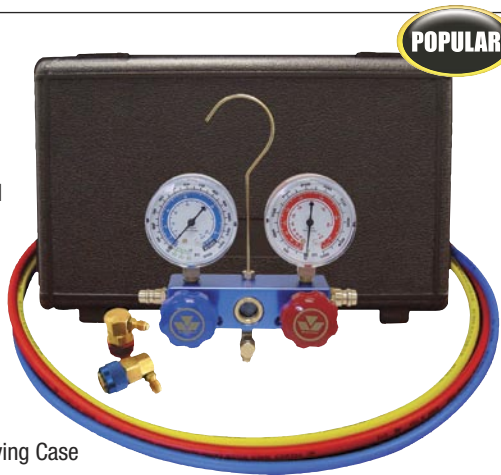

### 98660 DUAL R134a/R12 MANIFOLD GAUGE SET

- Professional Extruded Aluminum Block
- Silicone Dampened, Recalibrateable Gauges
- Set of 3 - R134a Nylon Barrier Hoses
- Set of 3 - R12 Nylon Barrier Hoses
- Professional R134a Couplers
- Custom Molded Carrying Case



### 98661 DUAL R134a/R12 MANIFOLD GAUGE SET

- Professional Extruded Aluminum Block
- Silicone Dampened, Recalibrateable Gauges
- Set of 3 - R134a Nylon Barrier Hoses
- Set of 3 - R12 Nylon Barrier Hoses
- Manual Couplers
- Custom Molded Carrying Case

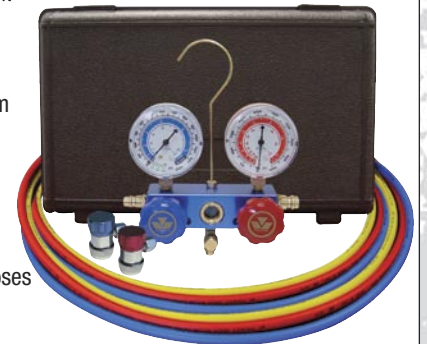

## 2-WAY MANIFOLDS W/ GAUGES ONLY

### 2 1/2" GAUGES

- 85103** R134a (1/2" ACME-M)  
**93103** R12, R22, R502 (1/4" FL-M)

### 3 1/8" GAUGES

- 85113** R134a (1/2" ACME-M)  
**93113** R12, R22, R502 (1/4" FL-M)

## PARTS FOR 2-WAY ALUMINUM MANIFOLDS

- 85215** O-rings for Al. Manifold (4 pcs)    **85216** Seal & Seat Assembly (2 pcs)



**Mastercool**<sup>®</sup>  
 "World Class Quality"

# BRASS 2-WAY MANIFOLD GAUGE SETS

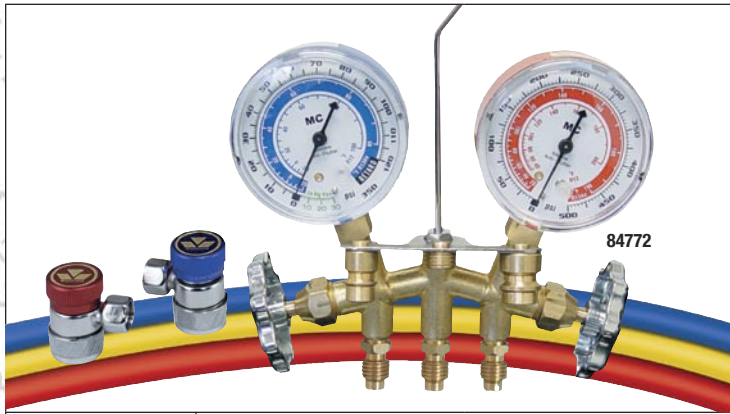

## R134a Auto A/C 2-way manifold gauge sets with hoses packaged in clamshells.

- Hose connections for blue and red are 14mm-M.
- Yellow hose is 1/2" ACME-F with auto shut-off valve.
- Gauges are 2 1/2" PSI/°F, 3 1/8" in PSI/Kpa & °F.

To order manifolds with shock-resistant gauge protectors, simply place a "-G" after the part number. (2 1/2" only)

HOSE LENGTH (SET OF 3)	W/MANUAL COUPLERS		W/E-Z SNAP™ COUPLERS		W/O COUPLERS	
GAUGE SIZE	2 1/2"	3 1/8"	2 1/2"	3 1/8"	2 1/2"	3 1/8"
36"	84636	84136	83436	83136	80636	80136
60"	84661	84161	83461	83161	80661	80161
72"	84772 <b>POPULAR</b>	84172	83472	83172	80772	80172

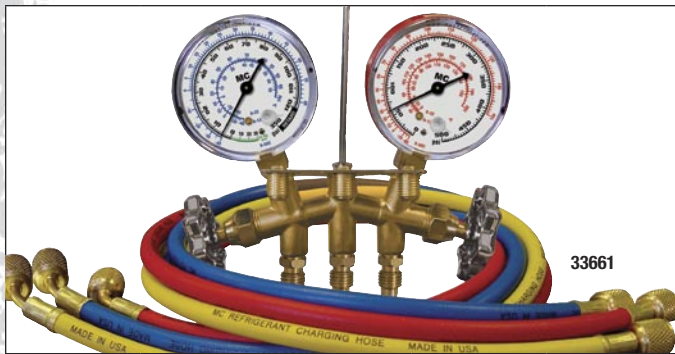

## R12, R22 and R502 2-way manifold gauge sets with hoses packaged in clamshells.

- Hose connections are 1/4" SAE.
- Gauges are 2 1/2" or 3 1/8" in PSI & °F.

To order manifolds with shock-resistant gauge protectors, simply place a "-G" after the part number. (2 1/2" only)

HOSE LENGTH (SET OF 3)	STANDARD HOSES STANDARD FITTINGS		STANDARD HOSES AUTO SHUT-OFF VALVES		NYLON BARRIER HOSES STANDARD FITTINGS		NYLON BARRIER HOSES AUTO SHUT-OFF VALVES		NYLON BARRIER HOSES MANUAL BALL VALVES	
	2 1/2"	3 1/8"	2 1/2"	3 1/8"	2 1/2"	3 1/8"	2 1/2"	3 1/8"	2 1/2"	3 1/8"
GAUGE SIZE	2 1/2"	3 1/8"	2 1/2"	3 1/8"	2 1/2"	3 1/8"	2 1/2"	3 1/8"	2 1/2"	3 1/8"
36"	33636	33136	35636	35136	36636	36136	37636	37136	32636	32136
60"	33661	33161	35661	35161	36661	36161	37661	37161	32661	32161
72"	33772	33172	35772	35172	36772	36172	37772	37172	32772	32172

## GAUGES

- 85350 R134a, R12 PSI/°F Low Side Gauge (2 1/2")
- 85500 R134a, R12 PSI/°F High Side Gauge (2 1/2")
- 93350 R12, R22, R502 PSI & °F Low Side Gauge (2 1/2")
- 93500 R12, R22, R502 PSI & °F High Side Gauge (2 1/2")
- 86350 R134a PSI/Kpa & °F Low Side Gauge (3 1/8")
- 86500 R134a PSI/Kpa & °F High Side Gauge (3 1/8")
- 91250 R12, R22, R502 PSI & °F Low Side Gauge (3 1/8")
- 91500 R12, R22, R502 PSI & °F High Side Gauge (3 1/8")

## AUTOMOTIVE R134a MANIFOLD GAUGE SETS WITH ECONOMY COUPLERS

- 66660 Brass R134a Manifold Gauge Set comes complete with 1 – 60" hose, 2 – 36" hoses and economy couplers. Packaged in a clamshell.
- 66661 Brass R134a Manifold Gauge Set comes complete with 3 – 60" hoses and economy couplers. Packaged in a clamshell.



## PARTS FOR 2-WAY BRASS MANIFOLD

- 34215 O-rings for Brass Manifolds
- 34216 Seal & seat assembly for brass manifolds

## BRASS MANIFOLDS W/GAUGES ONLY

- 33103 R12, R22, R502 2 1/2" (1/4" MFL)
- 33113 R12, R22, R502 3 1/8" (1/4" MFL)
- 80103 R134a 2 1/2" (1/2" ACME-M)
- 81113 R134a 3 1/8" (1/2" ACME-M)





Mastercool offers one of the most extensive lines of high quality replacement gauges. Our wide variety of gauge scales are available in different sizes and styles. All of our gauges are designed with the **ANTI-FLUTTER** feature that reduces needle fluctuation and increases reading accuracy.



85350



85500



93500



93350

### 2 1/2" GAUGE MODELS

MODEL#	COMPOUND (Low Side)	MODEL#	PRESSURE (High Side)	REFRIGERANT
85350	PSI/F	85500	PSI/F	R134a, R12
93350	PSI/F	93500	PSI/F	R12, R22, R502



91500



91250



86500



86350

### 3 1/8" GAUGE MODELS

MODEL#	COMPOUND (Low Side)	MODEL#	PRESSURE (High Side)	REFRIGERANT
86350	PSI/Kpa/F	86500	PSI/Kpa/F	R134a
91250	PSI/F	91500	PSI/F	R12, R22, R502

Mastercool gauge protectors are built to cushion shock due to rough handling. The unique ribbing deadens bumps and deflects shocks. Snug fitting. Color coded. All Mastercool manifold gauge sets are available with gauge protectors installed. To order, simply place a "-G" after any gauge set number.



### GAUGE PROTECTORS

COLOR	2 1/2" GAUGE	3 1/8" GAUGE
BLUE	93253-E	91253-E
RED	93503-E	91503-E
SET	93553-E	91553-E



### REPLACEMENT LENSES

85253-E Replacement Lens for 2 1/2" gauge

98251-E Replacement Lens for 3 1/8" gauge



**Mastercool**<sup>®</sup>  
"World Class Quality"

# CHARGING HOSES

Mastercool uses only **(GRADE 5 HOSE)** with a selection of Standard and Nylon Barrier for high pressure applications. Knurled brass nuts make finger tightening easy. **Crimped with 8 segment dies for secure fit and maximum durability.** Hoses are available in sets and a variety of lengths to meet all EPA, SAE and UL requirements for containment of refrigerant.



STANDARD & HIGH PRESSURE HOSES W/STANDARD FITTINGS (1/4" SAE)									
Standard Hoses, Working pressure 750 PSI, Burst 3000 PSI					Nylon Barrier Hoses, Working Pressure 800 PSI, Burst 4000 PSI				
HOSE LENGTH	36"	60"	72"	96"	HOSE LENGTH	36"	60"	72"	96"
Blue 1/4"	41361	41601	41721	41961	Blue 1/4"	47361	47601	47721	47961
Yellow 1/4"	41362	41602	41722	41962	Yellow 1/4"	47362	47602	47722	47962
Red 1/4"	41363	41603	41723	41963	Red 1/4"	47363	47603	47723	47963
Black 1/4"	N/A	N/A	N/A	N/A	Black 1/4"	47364	47604	47724	47964
Sets* 1/4"	40336	40360	40372	40396	Sets* 1/4"	47336	47360	47372	47396
Black 3/8"	N/A	N/A	N/A	N/A	Black 3/8"	48364	48604	48724	48964

\* Sets include one blue, one red and one yellow hose.



STANDARD & HIGH PRESSURE HOSES W/AUTOMATIC SHUT-OFF VALVE FITTINGS (1/4" SAE)									
Standard Hoses, Working pressure 750 PSI, Burst 3000 PSI					Nylon Barrier Hoses, Working Pressure 800 PSI, Burst 4000 PSI				
HOSE LENGTH	36"	60"	72"	96"	HOSE LENGTH	36"	60"	72"	96"
Blue 1/4"	45361	45601	45721	45961	Blue 1/4"	46361	46601	46721	46961
Yellow 1/4"	45362	45602	45722	45962	Yellow 1/4"	46362	46602	46722	46962
Red 1/4"	45363	45603	45723	45963	Red 1/4"	46363	46603	46723	46963
Black 1/4"	N/A	N/A	N/A	N/A	Black 1/4"	46364	46604	46724	46964
Sets* 1/4"	45336	45360	45372	45396	Sets* 1/4"	46336	46360	46372	46396

Auto shut-off valves automatically retain refrigerant in the service hose when they are removed from the system, meet EPA, SAE and UL standards for containment of refrigerant.

\* Sets include one blue, one red and one yellow hose.

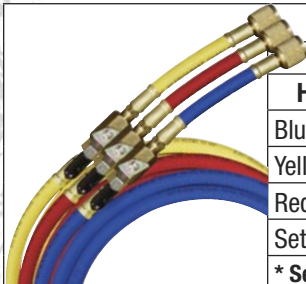

STANDARD & HIGH PRESSURE HOSES W/MANUAL SHUT-OFF VALVE FITTINGS (1/4" SAE)								
Standard Hoses, Working pressure 750 PSI, Burst 3000 PSI				Nylon Barrier Hoses, Working Pressure 800 PSI, Burst 4000 PSI				
HOSE LENGTH	36"	60"	72"	HOSE LENGTH	36"	60"	72"	
Blue 1/4"	90263-36	90263-60	90263-72	Blue 1/4"	49263-36	49263-60	49263-72	
Yellow 1/4"	90264-36	90264-60	90264-72	Yellow 1/4"	49264-36	49264-60	49264-72	
Red 1/4"	90265-36	90265-60	90265-72	Red 1/4"	49265-36	49265-60	49265-72	
Sets* 1/4"	90262-36	90262-60	90262-72	Sets* 1/4"	49262-36	49262-60	49262-72	

\* Sets include one blue, one red and one yellow hose.

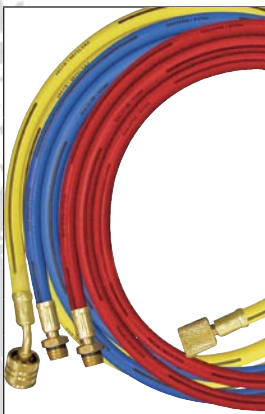

R134a HOSES WITH 1/2" ACME-F AND 14MM-M AUTO A/C FITTINGS				
HOSE LENGTH	36"	60"	72"	96"
Blue-14mm-M x 1/2" ACME-F	84361	84601	84721	84961
Yellow W/Shut-off Valve-1/2" ACME-F	84362	84602	84722	84962
Red-14mm-M x 1/2" ACME-F	84363	84603	84723	84963
Black-1/2" ACME-F	84364	84604	84724	84964
Black Conversion Hose 1/2" ACME-F x 1/4" FL-F	98364	98604	98724	98964
Yellow without Shut-off Valve	84365	84605	84725	84965
Sets*	84336	84360	84372	84396

Mastercool R134a charging hoses meet SAE J2196 specifications and are UL tested. Tested for working pressure of 600 PSI and burst pressure of 3000 PSI.

\* Sets include one blue, one red and one yellow hose.

Mastercool manufactures a complete line of shut-off valves for containment of refrigerant. EPA requires shut-off valves within 12 inches of the charging hose ends to prevent unnecessary venting of refrigerant. Using shut-off valves is much safer than allowing refrigerant to blow out during service.

## 90259 90° MANUAL SHUT-OFF VALVE SET

Needle valve design with flexible hose controls refrigerant with a twist of a knob. Meets SAE, EPA and UL requirements for containment of refrigerant. Screws onto charging hose end.

90° Manual Shut-Off Valve Set Includes:

- 90269** Blue 1/4 x 1/4"
- 90279** Yellow 1/4 x 1/4"
- 90289** Red 1/4 x 1/4"

### Also Available:

- 90389** Red 1/4 x 3/16"  
(Automotive)



## 90262 STRAIGHT MANUAL SHUT-OFF VALVE SET

Ball valve design with flexible hose controls refrigerant with a quarter turn of the valve handle. Meets SAE, EPA and UL requirements for containment of refrigerant. One hand operation. Screws onto charging hose end. Straight and Manual Shut-Off Valve Set includes:

- 90263** Blue 1/4 x 1/4"
- 90264** Yellow 1/4 x 1/4"
- 90265** Red 1/4 x 1/4"

### Also available:

- 90365** Red 1/4 x 3/16"

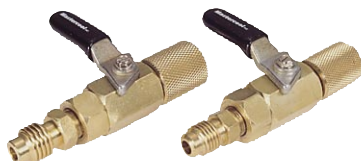

## MANUAL SHUT-OFF BALL VALVES

For custom application, Mastercool offers swivel ball valves without the hoses. This valve may be used to add shut-off valves to recycling equipment, manifold sets, flushing equipment, etc.

- 90430** 1/4 FL-F x 1/4 FL-M Swivel Ball Valve (less hose)
- 82495** 1/2" ACME x 1/2" ACME R134a Ball Valve (automotive less hose)



90333-R



90335-R

**QUICK DISCONNECT**  
No Loss of Refrigerant

## AUTOMATIC SHUT-OFF VALVES

Valve simply screws onto hose end. Available in straight and 90° models. Meets SAE, EPA and UL requirements for containment of refrigerant.

- 90333-R** 90° 1/4 FL-M x 1/4 FL-F
- 90333-UV** 90° 1/4" FFL x 13mm
- 90335-R** Straight 1/4 FL-M x 1/4 FL-F
- 90337** Straight 1/4 FL-M x 3/16 FL-F

## SERVICE HOSE REPLACEMENT PARTS

	1/4" SAE		1/2" ACME		14mm-M O-RING	UNF 1/2 - 20"	
	GASKET	DEPRESSOR	GASKET	DEPRESSOR		GASKET	DEPRESSOR
Charging Hoses	42010-10	42014-10	82010-10	42014-10	83341-10	42010-10	42014-10
Shut-Off Valve	90336-10	N/A	82336-10	N/A	N/A	N/A	N/A



**Mastercool**<sup>®</sup>  
"World Class Quality"



## ECONOMY COUPLERS

Specially designed to work in the tightest quarters. Attaches to your existing R12 hoses and snaps easily to A/C service ports.

- 66434-R** High Side R134a 1/4" FL-M x 16mm Economy Coupler
- 66534-R** Low Side R134a 1/4" FL-M x 13mm Economy Coupler
- 60034-10** O-ring for 66434 (10 pcs)
- 60134-10** O-ring for 66534 (10 pcs)

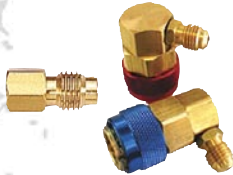

## 98370 R134a CONVERSION KIT

Includes High and Low Side R134a Couplers and R134a Tank Adapter.



## CONTROL VALVE

Ideal for use on charged systems. Eliminates refrigerant, oil or dye from spraying during connections. Brass body with 1/4" FFL swivel coupler.

- 90328** 1/4" FFL x 1/4" MFL

## MANUAL COUPLERS

Patented manual couplers adjust easily to R134a service ports with varying dimensions. All metal construction for extra durability. Patented, spring loaded depressor will not damage service valves. Can be removed from service ports regardless of knob position without losing refrigerant. Meets SAE, UL and EPA requirements for containment of refrigerant. Color coded. **PATENT# 5,370,359**



- 82834** High-Side Manual R134a  
14mm-F x 16mm Quick Coupler
- 82934** Low-Side Manual R134a  
14mm-F x 13mm Quick Coupler



- 82834-E** High-Side Manual R134a  
1/4" FL-M x 16mm Quick Coupler
- 82934-E** Low-Side Manual R134a  
1/4" FL-M x 13mm Quick Coupler

## REPLACEMENT O-RINGS

- 80034** O-ring for 16mm  
Quick Coupler (10 pcs)
- 80134** O-ring for 13mm  
Quick Coupler (10 pcs)

## E-Z SNAP™ COUPLERS

This unique patented design easily snaps on and off the A/C systems service ports under any pressure. The E-Z Snap™ automatically adjusts to various service port dimensions allowing fast and immediate access into the A/C system. The swivel feature enables the user to easily access all service ports, even in the tightest quarters. Meets SAE, UL, and EPA requirements for containment of refrigerant. **PATENT# 5,244,010**



- 82214** High-Side E-Z Snap R134a  
14 mm-F x 16mm Quick Coupler
- 82224** Low-Side E-Z Snap R134a  
14mm-F x 13mm Quick Coupler



- 82214-E** High-Side E-Z Snap R134a  
1/4" FL-M x 16mm Quick Coupler
- 82224-E** Low-Side E-Z Snap R134a  
1/4" FL-M x 13mm Quick Coupler

## REPLACEMENT O-RINGS

- 80034** O-ring for 16mm  
Quick Coupler (10 pcs)
- 80134** O-ring for 13mm  
Quick Coupler (10 pcs)

## MALE X MALE CONNECTORS

PART#	DESCRIPTION
<b>82734</b>	14mm-M x 1/4" FL-M (7/16-20") Connector
<b>82735</b>	14mm-M x M10 x 1.5-M Connector
<b>82736</b>	14mm-M x M12 x 1.75-M Connector
<b>82738</b>	14mm-M x 3/8" FL-M Connector
<b>83341</b>	O-Ring for 82733, 82734, 82735 and 82736
<b>80234</b>	O-Ring for 82634, 82634-M, 90364 and 90365



## FEMALE X MALE CONNECTORS

PART#	DESCRIPTION
<b>82635</b>	1/2" ACME-F x 1/4" FL (7/16-20")-M R134a Adapter Coupler
<b>82733</b>	14mm-F x 1/2" ACME-M Connector
<b>90364</b>	1/4" (7/16-20")-F x M10 x 1.5-M Adapter
<b>90363</b>	1/2-20 UNF-F x 1/4" FL-M Connector
<b>82634</b>	1/4" FL-F (7/16-20") x 1/2" ACME-M Connector
<b>82634-M</b>	1/4" FL-F (7/16-20") x 1/2" ACME-M R134a Connector





## 91207 CHARGING AND DEPRESSOR ASSORTMENT

Replacement gaskets, o-rings and depressors for charging hoses and adapters. Consists of:

- 42010** 1/4" Gasket (3 pcs)
- 42014** 1/4" Depressor (3 pcs)
- 90368** 3/16" Depressor (3 pcs)
- 90369** 3/16" Gasket (3 pcs)
- 90341** 1/8" O-ring (3 pcs)



## 85200 DELUXE A/C SERVICE REPAIR KIT

Replacement gaskets, depressors, o-rings and nylon guides for charging hoses and adapters. Consists of:

- 42010** 1/4" Gasket (10 pcs)
- 42014** 1/4" Depressor (10 pcs)
- 80034** O-ring for 82834 (10 pcs)
- 80034-1** High Side Nylon Guide (5 pcs)
- 80134** O-ring for 82934 (10 pcs)
- 80134-1** Low Side Nylon Guide (5 pcs)
- 82010** Gasket for R134a Hose (10 pcs)
- 82336** Gasket for 82335 (10 pcs)
- 83341** O-ring for R134a Hose (10 pcs)
- 90336** Gasket for R12 Shut-off Valve (10 pcs)



## 91334 CHARGING ADAPTER REPAIR KIT

55 piece assortment of replacement gaskets, o-rings and depressors for charging hoses and adapters. Consists of:

- 42010** 1/4" Gasket (10 pcs)
- 42014** 1/4" Depressor (10 pcs)
- 90368** 3/16" Depressor (10 pcs)
- 90369** 3/16" Gasket (10 pcs)
- 90341** 1/8" O-ring (10 pcs)
- 92107** Quick Disconnect Gasket (5 pcs)



## 91335 MASTER A/C CHARGING ADAPTER REPAIR KIT

126 piece assortment of replacement gaskets, o-rings and depressors for charging hoses and adapters. Also includes valve core removal tool and replacement valve cores. Consists of:

- 42010** 1/4" Gasket (20 pcs)
- 42014** 1/4" Depressor (20 pcs)
- 90368** 3/16" Depressor (20 pcs)
- 90369** 3/16" Gasket (20 pcs)
- 90341** 1/8" O-ring (20 pcs)
- 92107** Quick Disconnect Gasket (10 pcs)
- 0377-001** Refrigeration Valve Core (10 pcs)
- 90378** GM Large Bore Valve Core (5 pcs)
- 91290** Universal Valve Core Remover



## 91336 FORD SPRING LOCK REPLACEMENT O-RING AND GARTER SPRING ASSORTMENT

Compatible with R12 and R134a systems. Consists of:

- 1336-006** #6 O-ring (10 pcs)
- 1336-008** #8 O-ring (10 pcs)
- 1336-010** #10 O-ring (10 pcs)
- 1336-012** #12 O-ring (10 pcs)
- 1336-016** #6 Garter Spring (5 pcs)
- 1336-018** #8 Garter Spring (5 pcs)
- 1336-110** #10 Garter Spring (5 pcs)
- 1336-112** #12 Garter Spring (5 pcs)



## 91337 R12/R134a VALVE CORE REPAIR KIT

Replacement valve cores for valve core removers & installers. Consists of:

- 0377-001** Access Valve Core (20 pcs)
- 0378-001** Valve Core (10 pcs)
- 0531-001** R134a JRA High/Low Import Valve Core (10 pcs)
- 0768-001** R134a Domestic High Flow Valve Core M8 (5 pcs)
- 0769-001** R134a Domestic High Flow Valve Core M10 (5 pcs)
- 81290** R12/R134a Valve Core Remover/Installer (1 pc)



# CHARGING ADAPTERS, REPLACEMENT GASKETS, DEPRESSORS & RETROFIT ADAPTERS



90° ADAPTERS		REPLACEMENT	GASKET/O-RING	DEPRESSOR
A	90333-R	Shut-Off Valve 1/4" MFL x 1/4" FFL	90336	-
B	90314*	1/4" MFL x 1/4" FFL	42010	42014
B	90340*	1/4" MFL x 1/8" FFL (High Side) Ford 1977-1980	90341	90368
B	90354*	1/4" MFL x 3/16" FFL (High Side) GM 1976 & Later	90369	90368

45° ADAPTERS				
C	90924	1/4" MFL x 1/4" FFL	42010	42014
C	90927*	1/4" MFL x 3/16" FFL (High-Side)	90369	90368

STRAIGHT ADAPTERS				
D	82272*	R134a 1/2" ACME-F x 13mm (Low-Side)	85511	-
E	82335	R134a Shut-Off Valve 1/2" ACME-M x 1/2" ACME-F	90330/90336	-
E	90335-R	Shut-Off Valve 1/4" MFL x 1/4" FFL	90330/90336	-
E	90337	Shut-Off Valve 1/4" MFL x 3/16" FFL	90330/90331	-
F	82634*	1/4" FFL x 1/2" ACME-M	80234	-
F	82634-M	1/4" FFL x 1/2" ACME-M Without Valve Core	80234	-
G	82734	14mm-M x 1/4" MFL	83341	-
H	90358*	1/4" MFL x 3/16" FFL (High-Side)	42010	42014
I	90274	1/4" MFL x 1/4" FFL Swivel	42010	42014
I	90332**	1/4" MFL x 1/4" FFL Anti-Blowback Fitting	42010	42014
I	90357	1/4" MFL x 3/16" FFL (High-Side) Swivel	90369	90368
I	91084*	1/4" MFL x 3/16" FFL (High-Side) Swivel Adapter GM 1976 & Later, Ford 1981 & Later	90369	90368
J	90338*	GM 1991 & Later Service Adapter	90339	-
K	90637	3/4" NPSF x 1/4" MFL Refrigeration Tank Adapter	90638	-
L	90633	1/4" MFL x 1/4" MFL Union	-	-
L	82633	1/2" ACME-M x 1/2" ACME-M Union	-	-

FLEX ADAPTERS				
M	90355*	1/4" MFL x 3/16" FFL (High-Side) GM 1976 & Later, Ford 1981 & Later	90369	90368
M	90356*	1/4" MFL x 1/4" FFL	42010	42014
M	90373*	1/4" MFL x 1/8" FFL (High-Side) Ford 1977-1980	90341	90368
M	90410	1/4" MFL x 1/2" -20 UNF-FFL	82010	-

ACCESS SERVICE TOOLS				
N	90296*	1/4" MFL x 1/8" MPT	-	-
N	80296*	1/2" ACME-M x 1/8" MPT	-	-

\* Includes Access Valve Core (0377-001) – (90-110 PSI Opening)  
 \*\* Includes Check Valve Core (0332-002) – (8-12 PSI Opening)

## RETROFIT ADAPTERS



**82357 GM HIGH FLOW ADAPTER W/ VALVE CORE & SERVICE PORT CAPS**  
 GM High Flow Adapter



**INDIVIDUAL TERMINATION (BLOCK OFF CAPS)**  
**81297** 1/4" (7/16"-20)  
**81379** 3/16" (3/8"-24)

## STRAIGHT ADAPTERS W/VALVE CORE & SERVICE PORT CAPS

**82274** Low side, 1/4 (7/16" - 20) x 13mm  
**82332** High Side, 1/4 (7/16" - 20) x 16mm  
**82358** High Side, 3/16 (3/8" - 24) x 16mm



## 90° ADAPTERS W/VALVE CORE & SERVICE PORT CAPS

**82275** Low side, 1/4 (7/16" - 20) x 13mm  
**82333** High Side, 1/4 (7/16" - 20) x 16mm  
**82354** High Side, 3/16 (3/8" - 24) x 16mm



## 81174 UNIVERSAL RETROFIT ADAPTER ASSORTMENT

All **MASTERCool** retrofit adapters include built-in valves and caps. Universal A/C Retrofit Adapter Kit includes 15 low side adapters and 30 high side adapters. A larger quantity of high side retrofit adapters are included for the many different R12 high side service port configurations. This kit includes a selection of 90° adapters specially designed for tight quarters and 3 tools to make retrofitting easier. Kit includes:

### STRAIGHT ADAPTERS WITH VALVE CORE & SERVICE PORT ADAPTERS

QTY.	PART#	DESCRIPTION
10	82274	Low Side, 1/4" (7/16"- 20) x 13mm
5	82332	High Side, 1/4" (7/16"- 20) x 16mm
5	82357	GM High Flow Replacement
10	82358	High Side, 3/16" (3/8"- 24) x 16mm

### TERMINATION (BLOCK-OFF) CAPS

5	81297	1/4" (7/16"- 20)
5	81379	3/16" (3/8"- 24)

### 90° ADAPTERS WITH VALVE CORE & SERVICE PORT CAPS

QTY.	PART#	DESCRIPTION
5	82275	Low Side, 1/4" (7/16"- 20) x 13mm
5	82333	High Side, 1/4" (7/16"- 20) x 16mm
5	82354	High Side, 3/16" (3/8"- 24) x 16mm

### ACCESSORIES

10	81359	R134a Retrofit Information Labels
1	91338	GM Style High Flow Socket
1	91290	Universal Valve Core Remover & Installer
1	91390	R12 Thread Repair Kit
1	MC98RG	Retrofit Guidelines Booklet



## SERVICE TOOLS



### 85530 3-IN-1 SIDE MOUNT CAN TAP VALVE (US STANDARD)

This unique design covers 2 7/8" (R134a), 2 1/2" and 2" (OIL) charge cans. Includes 1/2" ACME-M and 1/4" FL-M ports. Internal safety check valve prevents system back flow.

### 85510 R134a CAN TAP VALVE - SCREW-ON MODEL (US STANDARD)

Screw-on design for R134a ACME male can taps. Gasket assures leak proof operation. Built-in safety check. Exclusive "full grip" valve knob. 1/2" ACME-M.



### 90925 CONDENSER FIN COMB

Cleans and straightens condenser and evaporator fins. Six sided head for 8, 9, 10, 12, 14 and 15 fins per inch applications.



### 93000 SPRING LOCK COUPLING TOOL SET

Four sizes 3/8" (#6), 1/2" (#8), 5/8" (#10) and 3/4" (#12) used on Fords and Chryslers. Durable spring loaded design for long life and reliable fit.

#### Set includes:

- 93098 3/8" (#6) Red
- 93099 1/2" (#8) Blue
- 93100 5/8" (#10) Black
- 93101 3/4" (#12) Beige



### 80011 HEAVY DUTY RATCHET HOSE CUTTER

Ratcheted action makes this cutter extremely easy to operate resulting in quick, clean cuts. Cutting blade is made of special alloy, heat treated steel for long life. Cuts all rubber hoses and PVC pipe up to 1/2" O.D. (Not recommended for PVC200)

80111 Replacement blade for 80011



### 80013 AUTOMOTIVE REFRIGERANT HOSE CUTTER

Makes quick, clean cuts. Cuts rubber automotive refrigerant hoses up to 1 1/2" O.D.

80113 Replacement blade for 80013



**Mastercool**<sup>®</sup>  
"World Class Quality"



## 58490 UNIVERSAL R12/R134a MASTER KIT



Allows the user to service valve cores without losing the systems charge. Kit covers all R12 & R134a system valve cores for Standard, JRA, Eaton and GM Large Bore.

PATENT# 6,253,436



## 58531 R134a STANDARD & JRA (M6) VALVE CORE KIT

Kit covers the most popular R134a valve cores.



## 58560 R134a EATON (M8 & M10) VALVE CORE KIT

Kit covers the Eaton style R134a valve cores.

## VALVE CORE REMOVERS/INSTALLERS AUTOMOTIVE/HVAC (1/4"FL)



### 91490 STANDARD VALVE CORE REMOVER/INSTALLER

Sturdy ball valve design controls refrigerant flow with 1/4 turn of the valve lever. Lever position also gives visual indication of whether valve is opened or closed.

## VALVE CORE REMOVERS & INSTALLERS

### 81290 R12/R134a UNIVERSAL LARGE BORE VALVE CORE REMOVER

Used on R12/R134a Standard and JRA/EATON Large Bore R134a Valve Cores.

### 91290 UNIVERSAL VALVE CORE REMOVER

Double ended for easy replacement of Standard and GM R12 Large Bore Valve Cores.

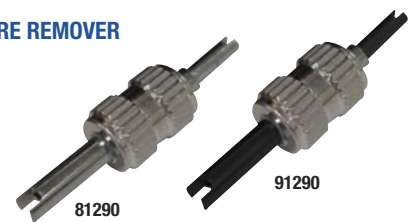

### 90376 VALVE CORE REMOVER W/VALVE CORES FOR R12

Quickly removes valve cores. Storage area includes six replacement access valve cores.

90377 Replacement Standard Valve Cores for 90376 (6 pcs of 0377-001)



### 91046-A A/C SYSTEM FLUSH KIT

Includes flush gun, hose, canister and canister adapter. Designed to work with any light weight flushing agent which can be mixed with pressurized air. Excellent for quickly and effectively removing refrigerant oil debris during retrofitting or compressor replacement.

### 91048 FLUSH CAPTURING UNIT

Special self adjusting tool to easily recover flush material for reuse or disposal. A unique rubber bladder coupler fits over the discharge lines of the component being flushed. As flush material leaves the A/C system, it is automatically collected for reuse or disposal.







30 LB. AND 50 LB. DOT-APPROVED RECOVERY CYLINDERS

Features:

- Powder coated cylinder for high gloss, durable finish
- Y-valve for liquid/vapor
- 3/4" NPT opening accepts 80% fill float switch shut-off device
- 1/4" opening for air purge valve
- Collar design for ease of handling
- Reusable and conforms to DOT-4BA400 specifications and ARI guidelines
- Australian Approved and TC Canadian (CAN/CSA-B339-02) Approved
- Pre-charged cylinder provides a clean, dry interior
- Storage and transport of recovered refrigerant gases
- Valve & Float Switch UL Listed

	30 lb.						50 lb.											
Model	62010 without float switch	62011 with float switch	62012 with float switch & NCG Port	64010 without float switch	67010 with float switch	67011 with float switch	63010 without float switch	65010 with float switch	66010 without float switch	66011 with float switch	66012 with float switch & NCG Port	63010-AUS without float switch (Australian standard)						
Connection	1/4" FL-M (7/16-20)			1/2" ACME			1/2" ACME			1/4" FL-M (7/16-20)			1/2" ACME					
Size (w x h)	9.125" x 17.52"			9.125" x 17.52"			9.125" x 17.52"			12.25" x 18.78"			12.25" x 18.78"			12.25" x 18.78"		
Tare Weight	17.99 LB			17.99 LB			17.99 LB			28.71 LB			28.71 LB			28.71 LB		
Standard Specification	DOT - 4BA400 CAN/CSA-B339-02			DOT - 4BA400 CAN/CSA-B339-02			DOT - 4BA400 CAN/CSA-B339-02			DOT - 4BA400 CAN/CSA-B339-02			DOT - 4BA400 CAN/CSA-B339-02			DOT - 4BA400		
Nominal Water Capacity	>26.2 LB / 11.9 L			>26.2 LB / 11.9 L			>26.2 LB / 11.9 L			>47.7 LB / 21.6L			>47.7 LB / 21.6L			>47.7 LB / 21.6L		
Service Pressure	400 PSI / 2.7 MPa			400 PSI / 2.7 MPa			400 PSI / 2.7 MPa			400 PSI / 2.7 MPa			400 PSI / 2.7 MPa			400 PSI / 2.7 MPa		
Tank Test Pressure	800 PSI / 5.5 MPa			800 PSI / 5.5 MPa			800 PSI / 5.5 MPa			800 PSI / 5.5 MPa			800 PSI / 5.5 MPa			800 PSI / 5.5 MPa		
Relief Valve Pressure	600 PSI / 4.1 MPa			600 PSI / 4.1 MPa			600 PSI / 4.1 MPa			600 PSI / 4.1 MPa			600 PSI / 4.1 MPa			600 PSI / 4.1 MPa		
Air Tightness Test Pressure	400 PSI / 2.7 MPa			400 PSI / 2.7 MPa			400 PSI / 2.7 MPa			400 PSI / 2.7 MPa			400 PSI / 2.7 MPa			400 PSI / 2.7 MPa		
Body Material	HP295			HP295			HP295			HP325 or HP345			HP325 or HP345			HP325 or HP345		
Color	yellow/gray			blue			yellow/blue			yellow/gray			yellow/gray			white		



# VACUUM PUMPS

A good quality vacuum pump is an integral tool for complete A/C service. Mastercool vacuum pumps are durable and time tested. They stand up to the most grueling conditions and will provide years of reliable service. Mastercool offers a complete selection of pumps. Regardless of your service requirements, Mastercool has a model for your application.

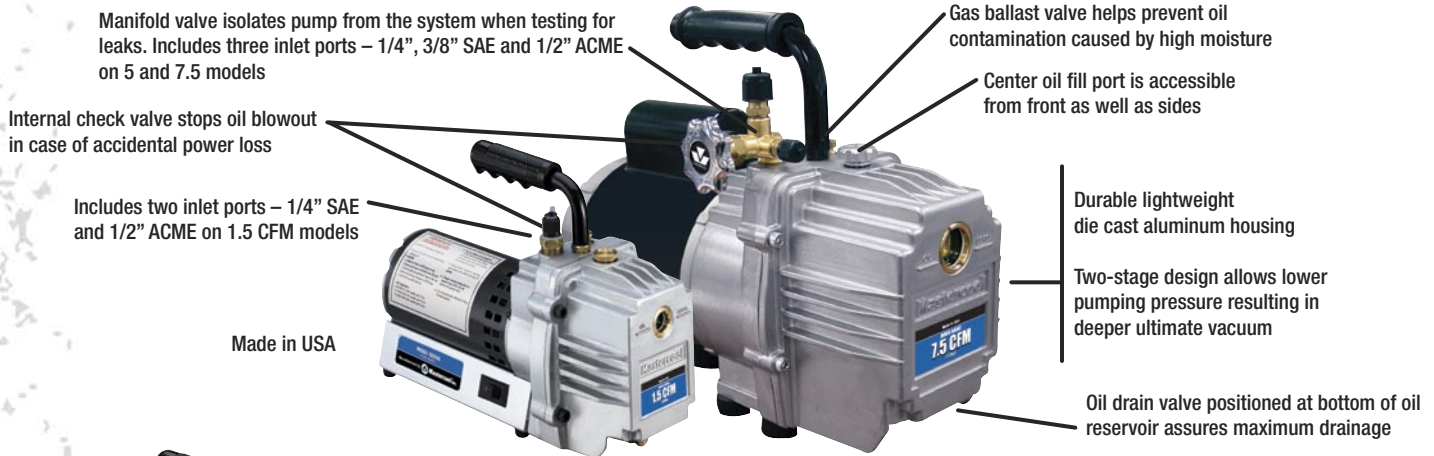

## 90060 1.5 CFM VACUUM PUMP (TWO STAGE)

This lightweight and easy to store vacuum pump (12lbs) is ideal for less than 3lb capacity evacuation. The inlet ports include 1/4" FL and 1/2" ACME (for automotive R134a systems.)



90060

Model #	NO OF STAGES	FREE AIR DISPLACEMENT	ULTIMATE VACUUM	PUMP MOTOR	PUMP SPEED	ELECTRICAL SPECS	SHIPPING WEIGHT
90060	2	1.5 CFM	50 MICRONS	1/6HP	3450 RPM	110 / 60HZ	12 lbs

## 90065 5 CFM VACUUM PUMP (TWO STAGE)

This model is an excellent choice for small to medium sized systems (2.5 lb to 10 lb charge capacity). This two stage pump features a manifold valve to isolate it from the system and three inlet ports: 1/4" flare, 3/8" flare and 1/2" ACME (for automotive R134a systems).

Model #	NO OF STAGES	FREE AIR DISPLACEMENT	ULTIMATE VACUUM	PUMP MOTOR	PUMP SPEED	ELECTRICAL SPECS	SHIPPING WEIGHT
90065	2	5 CFM	25 MICRONS	1/3HP	1725 RPM	110 / 60HZ	32 lbs



90065

## 90067 7.5 CFM VACUUM PUMP (TWO STAGE)

This model is the choice for medium sized and larger systems (5 lb and above charge capacity). The 1/2 horsepower motor makes cold condition start up quick and easy. This two stage pump features a manifold valve to isolate it from the system and three inlet ports: 1/4" flare, 3/8" flare and 1/2" ACME (for automotive R134a systems).



90067

Model #	NO OF STAGES	FREE AIR DISPLACEMENT	ULTIMATE VACUUM	PUMP MOTOR	PUMP SPEED	ELECTRICAL SPECS	SHIPPING WEIGHT
90067	2	7.5 CFM	25 MICRONS	1/2HP	1725 RPM	110 / 60HZ	34 lbs

## 91200 AIR OPERATED LIGHT DUTY VACUUM PUMP

Requires 4.5 CFM/90 PSI shop air. No moving parts, no oil required, 1.3 CFM air displacement venturi type pump will pull up to 29 inches of vacuum (Hg.) at sea level. Includes 1/4" flare (R12) connection and 1/2" ACME (R134a) connection.



## REPLACEMENT CARTRIDGE

SERVICE INFORMATION	1.5 CFM	5 CFM	7.5 CFM
OIL CAPACITY	10 oz	18 oz	24 oz
REPL. CARTRIDGE	90160-R	90165-R	90167-R

## 82031 VACUUM PUMP SWIVEL ADAPTER

"T" style adapter screws onto existing 1/4" flare fitting and converts to 1/4"-FL and 1/2" ACME



## ECONOMY SERIES

- High volume fan provides cool air to motor and pump
- Vapor discharge/oil fill port, easily removable, contains internal check valve to prevent escape of liquid oil
- Non-slip cushion handle
- Includes T-fitting with 1/4" flare and 1/2" ACME ports

- Cooling fins to keep temperature cooler during extended motor operation
- Manifold valve isolates pump from the system testing for leaks. Includes 3 inlet ports, 1/4", 3/8" SAE and 1/2" ACME.
- Gas ballast valve helps prevent oil contamination caused by high moisture (90066-2V-110 & 90070-2V-110)



<b>Model</b>	<b>90059-R</b>
<b>No. of Stages</b>	1
<b>Free Air Displacement</b>	1.5 CFM
<b>Ultimate Vacuum</b>	100 Microns
<b>Motor</b>	1/6 HP
<b>Pump Speed</b>	3450 RPM
<b>Electrical Specs</b>	110 V/ 60 HZ
<b>Shipping Weight</b>	16 lbs.



<b>Model</b>	<b>90062-A</b>
<b>No. of Stages</b>	1
<b>Free Air Displacement</b>	3 CFM
<b>Ultimate Vacuum</b>	75 Microns
<b>Motor</b>	1/4 HP
<b>Pump Speed</b>	1720 RPM
<b>Electrical Specs</b>	110 V/ 60 HZ
<b>Shipping Weight</b>	17 lbs.



<b>Model</b>	<b>90066-A</b>
<b>No. of Stages</b>	1
<b>Free Air Displacement</b>	6 CFM
<b>Ultimate Vacuum</b>	75 Microns
<b>Motor</b>	1/4 HP
<b>Pump Speed</b>	1720 RPM
<b>Electrical Specs</b>	110 V/ 60 HZ
<b>Shipping Weight</b>	22 lbs.

<b>Model</b>	<b>90066-2V-110</b>
<b>No. of Stages</b>	2
<b>Free Air Displacement</b>	6 CFM
<b>Ultimate Vacuum</b>	15 Microns
<b>Motor</b>	1/3 HP
<b>Pump Speed</b>	3440 RPM
<b>Electrical Specs</b>	110/220V 50/60 HZ
<b>Shipping Weight</b>	24.6 lbs

90066-2V-110



<b>Model</b>	<b>90070-2V-110</b>
<b>No. of Stages</b>	2
<b>Free Air Displacement</b>	10 CFM
<b>Ultimate Vacuum</b>	12 Microns
<b>Motor</b>	1/2 HP
<b>Pump Speed</b>	3440 RPM
<b>Electrical Specs</b>	110/220V 50/60 HZ
<b>Shipping Weight</b>	33 lbs.

90070-2V-110



## VACUUM PUMP OIL

PART#	DESCRIPTION
90010-6	Case of Six (10 oz bottles)
90018-6	Case of Six (18 oz bottles)
90024-6	Case of Six (24 oz bottles)
90032-6	Case of Six (32 oz bottles)
90128-4	Case of Four (1 gallon bottles)



## 98061 Digital Vacuum Gauge in blow molded case 98061-C Digital Vacuum Gauge in clamshell

### SPECIFICATIONS:

- Response Time: 250 mSec.
- Thermocouple Sensor Cable: 6.5 ft
- Connection Fitting: 1/4" FL-F adapter
- Operating Temperature: 32 - 120°F
- Battery Life: 36 hours
- Range: 20,000 to 1 micron
- Power: 9V DC battery
- Vacuum Units: Micron, Torr, mTorr, mmHg, mBar, Pa
- Accuracy Range\*: ATM - 1000 Microns: ±5% of reading  
1000 - 100 Microns: ±3% of reading / 100 - 1 Micron: ±1.5% of reading

\*Unit accuracy established using calibrated instrument with NIST traceability.

### OPTIONAL ACCESSORIES

98061-SENSOR  
Replacement Sensor

99334-110  
110V AC/DC Adapter

99333  
1/4 FL-M x 1/4 FL-M x 1/4 FL-F Tee

99334-220  
220V AC/DC Adapter



**Mastercool®**  
"World Class Quality"



## 98210-A ACCU-CHARGE II

Mastercool ACCU-CHARGE II, the most advanced electronic refrigerant scale in the market today. Constructed with a rugged aluminum cast body, the ACCU-CHARGE II now offers programming capabilities.



Adjustable Leveling Feet

### FUNCTIONS:

**CHARGE PROGRAMMING:** Allows user to program desired quantities. Before charge is complete, an alarm will sound allowing user ample time to turn off refrigerant supply.

**TANK CAPACITY PROGRAMMING:** Allows user to know the amount of refrigerant that is left in the tank at any time.

**REPEAT:** Allows user to charge previously stored amount.

### SPECIFICATIONS:

- Capacity: 240 lbs (110 kg)
- Accuracy:  $\pm 0.01$  kg  
 $\pm 0.16$  oz  
 $\pm 0.01$  lb } or 0.1% of reading (whichever is greater)
- Resolution: 0.01 kg / 0.02 lb
- 3 hrs Auto Off Function
- Operating Temperature is 32 to 120°F (0 to 49°C)
- Battery Life (approximately 40 hrs)
- Works w/110 or 220V Transformer (not available)
- 9 x 9" (22 x 22 cm) Platform

## 98211-A ACCU-CHARGE III CERTIFIED REFRIGERANT SCALE (OIML & CE Approved, Legal for Trade)



Adjustable Leveling Feet

**CHARGE PROGRAMMING:** Allows user to program desired quantities. Before charge is complete, an alarm will sound allowing user ample time to turn off refrigerant supply.

**PAUSE/CHARGE:** (Using the 98230 Charging Solenoid Module)

**TANK CAPACITY PROGRAMMING:** Allows user to know the amount of refrigerant that is left in the tank at any time.

**REPEAT:** Allows user to charge previously stored amount.

### SPECIFICATIONS:

- Complies with European (OIML) Standards
- Capacity: 110 lbs (50 kg)
- Accuracy:  $\pm 50$  g
- Resolution: 0.10 lbs (0.05 kg)
- 3 hrs AUTO OFF Function
- Operating Temperature is 32 to 120°F (0 to 49°C)
- Battery Life (approximately 40 hrs)
- 9 x 9" (22 x 22 cm) Platform

## 98230 CHARGING SOLENOID MODULE

The 98230 Charging Solenoid Module turns the 98210-A ACCU-CHARGE II & 98211-A ACCU-CHARGE III into Automatic Programmable Scales!

This module allows the user to control the exact amount of refrigerant transferring to and from the A/C System. The compact design is battery powered (9V), lightweight, portable and works with all types of refrigerant. 98230 includes a short hose for tank connection, USB cord and 1/4" FL - 1/2" ACME adapters.



## SMART CHARGE™

The "Smart-Charge" scale does it all! Program and automatically transfer refrigerant to and from the A/C system. The capacity of over 700 models of cars from around the world is contained in the scale's memory. With the easy to use keypad you can retrieve almost any refrigerant capacity from automobiles made from 1989-UP.

**98300** 110 Volt  
**98300-220** 220 Volt

### SPECIFICATIONS

Capacity: 110 Lb or 176 Lb  
 Accuracy: ±1% of reading  
 Resolution: .02 Lb at 110 Lb capacity or .04 Lb at 176 Lb capacity  
 Weight: 12 Lb  
 Size: 17 x 12 x 4"  
 Power: 115V or 220V  
 Platform: 8.6 x 8.6"

### FEATURES

**LANGUAGES:** The scale will display operating commands in seven different languages: English, Spanish, Portuguese, Italian, German, French and Swedish.

**MEMORY:** The scale will retain 3 weights in it's memory,

- Tare weight (weight of the empty cylinder)
- Net weight (weight of the refrigerant)
- Gross weight (Tare weight + Net weight)

At any time, the user can recall these three weights to determine the status of refrigerant.

**CHARGING:**

1. Unit can be programmed manually or by selecting one of over 700 vehicle refrigerant capacities stored in the memory.
2. Once programmed the unit will automatically stop the flow of refrigerant when the charge is complete.
3. The unit will also let you know if there is not enough refrigerant in the cylinder to supply the current charge.
4. If the same amount of charge is required, the "REPEAT" key can be used.

**RECOVERY:**

1. The unit will automatically monitor the amount of refrigerant that has been recovered.
2. If the cylinder is full, the unit will notify the user.

**VACUUM:**

1. Plug vacuum pump into the convenient outlet on the scale and program in your vacuum time.
2. Once the program time has ended the vacuum pump will shut off and the display will notify the user.

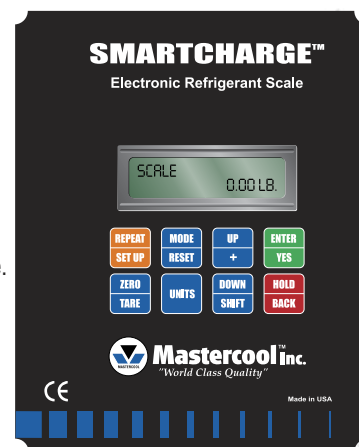

## ELECTRONIC TANK HEATER BLANKET

The Mastercool Refrigerant Tank Heater Blanket speeds up recharging time.

- Assures total discharge of refrigerant from 30 lb and 50 lb tanks of 125°F and maximum pressure of 185 PSI (R134a) and 170 PSI (R12)
- Quick working 300W heater element
- An excellent complement to all Mastercool Refrigerant Scales

**98250** 110V  
**98250-220** 220V



## 98100 AIR CONTENT ANALYZER

When an A/C system leaks, refrigerant is lost and air enters the system. Your refrigerant recycler cannot tell the difference between refrigerant and air - it recycles both from partially filled systems. You end up with an unknown quantity of efficiency robbing air in your supply tank. Excess actual pressure in your supply tank, indicates the pressure of air also called "non-condensable gases" or NCG's. When you release the excess pressure, you are releasing air. The result is purer refrigerant, which will work more efficiently.

The Mastercool Air Content Analyzer is more accurate than most automatic purging systems. It can be left on your supply tank for regular monitoring or it can be removed to check all your tanks.



**Mastercool®**  
 "World Class Quality"

## REFRIGERANT RECOVERY SYSTEM

Mastercool's professional recovery systems are compact, lightweight and work with all refrigerants. They're ideal for commercial, residential or industrial appliance applications. Our recovery systems offer a state-of-the-art 1/2 HP oil-less compressor with a built-in high volume cooling fan. This new innovative design delivers maximum cooling efficiency which keeps the compressor working at high capacities in even the hottest climates. The compressor is also protected by an automatic low pressure cut-off switch that shuts off the unit once the recovery is complete. This AUTO SHUT-OFF feature eliminates the risk of compressor failure and reduces the user's need to monitor the entire recovery system. All of our recovery systems offer our newest color-coded gauges with pressure readings in PSI, BAR and Mpa. Our stainless steel ball valve designed manifold controls the flow smoothly and quickly with only a 1/4 turn. With all of this protected by a reinforced hard plastic case, Mastercool's new recovery systems will meet all your refrigerant recovery needs.

**69000** 115V – 60Hz **69000-220** 220V – 50/60Hz

**POPULAR**



### FEATURES:

- High performance oil-less compressor
- High volume cooling fan design
- Automatic low pressure Cut-Off Switch
- Liquid compatible head-valve system
- Safety high pressure Cut-Off Switch
- Fully reinforced hard plastic casing
- Made in USA

### SPECIFICATIONS:

- 1/2 HP oil-less compressor
- Recovery Rate
  - direct vapor up to 3/4 lb/m
  - direct liquid up to 2 1/2 lb/m
  - push-pull up to 12 lb/m
- Operating temp. range: 32 to 122°F
- Weight: 38 lbs • Dim.: 17" L x 10" W x 12" H
- Refrigerants: CFC's, HCFC's, HFC's

## 69100 COMPLETE A/C RECOVERY SYSTEM

The 69100 Professional Recovery System is compact, lightweight and works with all refrigerants. It offers a State of the Art 1/2 hp Oil-less Compressor with a built-in High Volume Cooling Fan. This innovative design delivers maximum cooling efficiency which keeps the compressor working at high capacities in even the warmest climates. The Compressor is protected by an Automatic Low Pressure Cut-off Switch that Shuts Off the Unit once the recovery is complete. This Auto Shut-off Feature eliminates the risk of compressor failure and reduces

the user's need to monitor the entire recovery process. The 69100 also includes an Oil Separator and Filter Dryer to cleanse the refrigerant during the recovery process. The Mastercool Recovery System offers our newest color-coded gauges with Pressure Readings in PSI, BAR and MPA. The Stainless Steel Ball Valve designed Manifold controls the refrigerant flow smoothly and quickly with only a 1/4 turn. All of the internal components have been arranged and isolated to ensure a smooth and quiet performance. With all of this protected by a reinforced hard plastic case, Mastercool's Recovery System will meet all of your refrigerant needs.

**POPULAR**



### FEATURES & BENEFITS:

- High performance oil-less compressor
- High volume cooling fan design
- Automatic low pressure Cut-Off Switch
- Liquid compatible head-valve system
- Safety high pressure Cut-Off Switch
- Fully reinforced hard plastic casing
- Made in USA

**Design Certified to Meet SAE J2810**

## 69110 AUTOMOTIVE A/C RECOVERY SYSTEM

- Includes Recovery Unit, 30 lb DOT Tank, a 60" Yellow Service Hose, 72" Blue and Red Conversion Hoses, UL Approved High and Low Side R134a Manual Couplers and Oil Purge Bottle
- Designed to meet SAE J2810 and works with all refrigerants.
- Recovers and removes oil from refrigerant.
- All internal components have been arranged and isolated to ensure smooth and quiet performance.
- State of the art 1/2 hp oil-less compressor with built-in high volume cooling fan.
- Delivers maximum cooling efficiency, keeping compressor working at high capacities even in warmest climates.
- Compressor protected by automatic low pressure cut-off switch eliminating risk of compressor failure and reducing need to monitor entire recovery process.
- Stainless steel ball valve design manifold controls refrigerant flow smoothly and quickly with only 1/4 turn.
- Gauges provide pressure readings in PSI, BAR and MPA.

### SPECIFICATIONS:

- Refrigerant R134a
- High Side Design Pressure 500 psig
- Low Side Design Pressure 174 psig
- 115 Volts AC
- 1 PH, 60 HZ., 8.6 Amps, 1.25 S/F
- Service Factor 10.75 AMP
- Made in USA

**NEW!**



### SPECIFICATIONS:

- 69100: 115V – 60Hz
- 69100-220: 220V – 50/60 Hz
- 1/2 HP Oil-less Compressor
- Recovery Rate
  - direct vapor up to: 3/4 lb/m (.34 kg/m)
  - direct liquid up to: 2 1/2 lb/m (1.13 kg/m)
  - push-pull up to: 12 lb/m (5.5 kg/m)
- Operating temp range: 32-122°F/0 to 50°C
- Refrigerants: All
- Weight: 38 lbs
- Dimensions: 17" L x 10" W x 12" H

# TWINTURBO

REFRIGERANT RECOVERY MACHINE

69300 115V - 60 HZ      69300-220 220V - 50/60 HZ



**Specifications:**

- 1/2 hp oil less compressor
- Recovery rate:
  - Direct vapor up to .39 kg/min
  - Direct liquid up to 3.1 kg/min
  - Push pull up to 8.1 kg/min
- Operating Temperature: 0 to 50°C
- Weight: 11 kg (25 lbs)
- Dimensions: 457mm (l) x 254mm (w) x 356mm (h) (18" (l) x 10" (w) x 14" (h))
- Case Material is HDPE (High Density Polyethylene)
- Compatible refrigerants: All CFC, HCFC, and HFC's

Mastercool introduces its newest addition to the recovery machine lineup. Taking the reliability of the 69000 series machines, Mastercool has enhanced those features to allow for maximum recovery capacity while at the same time decreasing size and weight. The design of the new double piston compressor and cooling by the largest fan and condenser in the market makes the new 69300 series the most complete solution to your recovery needs!

**Features & Benefits:**

- Revolutionary double piston oil-less compressor
- Auto low pressure switch for durability of compressor
- Safety high pressure switch
- Simple internal structure for field service
- Largest volume recovery rate in market
- For use with all refrigerants including R410A
- Injection molded high density polyethylene case for maximum durability
- Large ergonomically positioned gauges for easy reading
- Front cover has bumper guards built in to reduce damage to the control knobs

**RECOVERY RATE MARKET COMPARISONS**

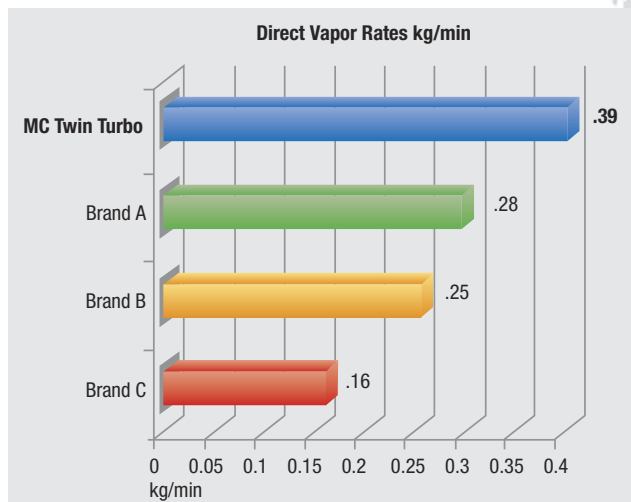

69360 115V - 60HZ  
69360-220 220V - 50/60 HZ

This unit offers all the same functions and features as the 69300 in addition it has an oil separation module, filter dryer and sight glass.

69500-DR Replacement Filter Dryer

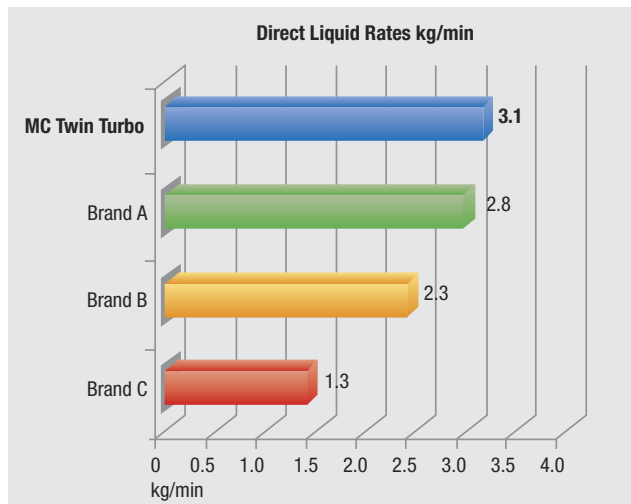

**Mastercool**<sup>®</sup> Inc.  
"World Class Quality"



## 69500 RECOVERYMATE

**Speed up the recovery process!** Remove unwanted moisture and separate oil from Recovered Refrigerant. (Use with any Recovery Machine.)

### SPECIFICATIONS:

- Lightweight and easy to carry
- 4-Way Ball Valve Manifold controls the flow smoothly and quickly with only 1/4 turn
- Large capacity oil separator
- High Performance Dryer eliminates moisture from recovered refrigerant
- Extra large sight glass monitors refrigerant flow and changes color when a dryer change is necessary
- Rugged carrying case can stand on its own or be mounted on a wall or bench
- Length: 15" / Width: 4" / Height: 17"
- Weight: 5.5 kg (12.25 lbs)

## PORTABLE ELECTRONIC CHARGING STATIONS

A lightweight, durable, steel frame cart that contains all the necessary tools to quickly and conveniently charge the A/C system. No need for different sized charging cylinders with Mastercool's rugged die cast electronic scale. Simply place the refrigerant cylinder on the scale and charge.

### FEATURES:

- A rugged, lightweight steel cart with wheels and convenient storage pocket for scale and hoses allows this portable charging station to be taken almost anywhere
- 240 lb capacity scale with long lasting 9V battery (60 hrs)
- Deep micron, rotary vane vacuum pumps.
- Extruded aluminum manifold with long lasting valve design

### 2 STAGE PORTABLE ELECTRONIC CHARGING STATION

- Large 3 1/8" gauges make it easy to read the pressure and temperature scales
- Deep micron, rotary vane vacuum pumps  
Available in 1.5, 5 and 7.5 CFM
- Includes set of 72" hoses

Also available:

- Refrigerant tank heater blanket #98250 and #98250-220
- D.O.T. cylinder #62010-R12 w/o float

\* R134a Automotive Service Couplers not included

\* 220V units with metric gauges are available. Please specify.

VACUUM PUMP	1.5 CFM 110V	5 CFM 110V	7.5 CFM 110V
MANIFOLD			
2 Way Alum Block	<b>91580</b>	<b>91585</b>	<b>91587</b>
4 Way Alum Block	<b>91581</b>	<b>91586</b>	<b>91588</b>



## MOBILE ELECTRONIC CHARGING STATION

Keeping the same ideals in mind as the Portable Electronic Charging Station, Mastercool introduces its new mobile unit directed towards the garage technician. With an enlarged carry cart and larger wheels, this new unit can get around the shop with the greatest of ease!

VACUUM PUMP	1.5 CFM
MANIFOLD	110V
2 Way Alum Block	<b>91680</b>
4 Way Alum Block	<b>91681</b>

VACUUM PUMP	5 CFM
MANIFOLD	110V
2 Way Alum Block	<b>91685</b>
4 Way Alum Block	<b>91686</b>

VACUUM PUMP	7.5 CFM
MANIFOLD	110V
2 Way Alum Block	<b>91687</b>
4 Way Alum Block	<b>91688</b>



**NEW!**

### SINGLE STAGE PORTABLE ELECTRONIC CHARGING STATION

- 2 1/2" gauges
- Deep micron, rotary vane vacuum pumps.  
Available in 1.5, 3 and 6 CFM

Also available:

- Refrigerant tank heater blanket #98250 and #98250-220

91580-A	91580-B	91585-B
R134a 2-way Manifold	R134a 2-way Manifold	R134a 2-way Manifold
1.5 CFM Single Stage Vacuum Pump	3 CFM Single Stage Vacuum Pump	6 CFM Single Stage Vacuum Pump
Electronic Charging Scale	Electronic Charging Scale	Electronic Charging Scale
Manual Couplers	Manual Couplers	Manual Couplers
Set of Hoses	Set of Hoses	Set of Hoses





### 69788 RECOVERY/RECYCLE/RECHARGE

- Quality Performance Year after Year
- Design Certified for Compliance with SAE J2788  
New A/C systems are smaller. Machines must charge within .5 oz and recover 95% of the refrigerant.
- Automatic/Programmable or Manual  
The 69788 can be programmed to complete a continuous recovery/recycle, vacuum, vacuum leak test and recharge. The machine can also be set to run each operation individually.
- Includes Refrigerant Capacity Database (over 1000 vehicles)  
Includes refrigerant capacities for US and Import makes and models from 1998 to 2010. The 69788 is capable of software upgrades as well.
- Auto Vacuum Leak Test  
Pauses cycle and monitors vacuum level to inform the technician of possible leaks.
- Auto Oil Discharge  
Oil is automatically discharged during the recovery process into a graduated container clearly displaying the amount of oil that was removed during the recovery process.
- Auto Air Purge  
Automatically purges air from the tank upon initial start-up or when the tank pressure is too high.
- Auto Filter Alarm  
The machine's LCD and alarm will warn that a filter change is required.
- Compact Footprint  
The machine's compact design makes it easy to maneuver and requires minimal shop space.

#### SPECIFICATIONS:

- 115 V / 60 Hz
- 6 CFM Vacuum Pump
- Internally mounted 30 lb. DOT tank
- Dimensions: 41" H x 24" W x 22" D
- Weight: 187 lbs.

#### 69788-FLTRPK

Filter pack for 69788



**Mastercool**<sup>®</sup>  
"World Class Quality"

# UV LEAK LOCATOR KITS

## COMPACT UV LEAK LOCATOR KITS

Leading the way in UV LEAK DETECTION, Mastercool offers a variety of compact UV Leak Locator Kits. Each kit offers a powerful inspection lamp, a "Refillable" or "Cartridge Type" Dye Injector and accessories. All kits are packaged in a clamshell or custom molded carrying case.



	TYPE OF INJECTOR / TYPE OF LIGHT	KIT PART#	CONTENTS OF EACH KIT	VOLTAGE/WATT
	53123/53012 	53100	High Intensity Swivel Head Light, W/ Refillable 2 oz Dye Injector, 2 oz Concentrated Universal A/C Fluorescent Dye (25 Appl.), 4 oz Dye Remover, 25 Service Information Labels & UV Enhancing Safety Glasses	12V/100 WATT
	53223/53012 	53100-C	Same as 53100, but with Replaceable 2 oz Dye Cartridge (25 Applications)	12V/100 WATT
	53123/53411 	53450	High Intensity Cordless Rechargeable Light W/ Battery Charger, Refillable 2 oz Dye Injector, 2 oz Concentrated Universal A/C Fluorescent Dye (25 Applications), 4 oz Dye Remover, 25 Service Info. Labels & UV Enhancing Safety Glasses	12V/50 Watt 110V Battery Charger
	53223/53411 	53450-C	Same as 53450, but with Replaceable 2 oz Dye Cartridge (25 Applications)	12V/50 Watt 110V Battery Charger

	<p>53123/53312</p> 	<p>53500</p>	<p>High Intensity Mini Light W/Refillable 2 oz Dye Injector, 2 oz Concentrated Universal A/C Fluorescent Dye (25 Applications), 4 oz Dye Remover, 25 Service Info. Labels. &amp; UV Enhancing Safety Glasses</p>	<p>12V/50 WATT</p>
	<p>53223/53312</p> 	<p>53500-C</p>	<p>Same as 53500, but with Replaceable 2 oz Dye Cartridge (25 Applications)</p>	<p>12V/50 WATT</p>
	<p>53809/53515</p> 	<p>53580</p>	<p>MACH IV Flexible LED UV Light W/1 oz Dye Injector, W/Replaceable 1 oz Dye Cartridge (10 Application), Low-Side Hose W/R134a Coupler, R12 Adapter, 10 Service Info. Labels &amp; UV Enhancing Safety Glasses</p>	<p>2 - CR2 Lithium 3V Batteries</p>
	<p>53809/53515</p> 	<p>53585</p>	<p>Same as above, but W/1 oz OIL/ATF/Gas (53610) &amp; Diesel Fluorescent Dye and 1 oz (30ml) Engine Coolant Fluorescent Dye (53609)</p>	<p>2 - CR2 Lithium 3V Batteries</p>
	<p>53809/53312</p> 	<p>53351</p>	<p>High Intensity Mini Light with Replaceable 1 oz (10 application) Dye Cartridge, A/C Connection Hose w/R134a Coupler, R12 Adapter, 1 oz OIL/ATF/Gas and Diesel Fluorescent Dye, 1 oz Engine Coolant Dye, 4 oz Dye Remover, 25 Service Information Labels and UV Enhancing Safety Glasses</p>	<p>12V/50 WATT</p>



## 53012 UV SWIVEL HEAD LIGHT (12V/100 WATTS)

- 180° Swivel Heads Get Into Tight Places
- Instant ON
- Heavy Duty Metal Construction
- Includes UV Enhancing Safety Glasses



## 53312 UV MINI LIGHT (12V/50 WATTS)

- High Intensity
- 16ft. Cord
- Compact & Lightweight
- Includes UV Enhancing Safety Glasses
- Instant ON



## RECHARGEABLE UV LIGHT

### 53411 (12V/50 WATTS)

- High Intensity
- Compact & Portable
- Cordless with Rechargeable Battery
- Includes UV Enhancing Safety Glasses



### 53412 (12V/50 WATTS)

- Same as 53411 (less battery cartridge and glasses)

## 53515 MACH IV FLEXIBLE UV LIGHT

The Mach IV flexible UV light has **4 TRUE UV LEDS** delivering a brilliant fluorescent glow.

- Gets into tight areas easily.
- Rugged Ergonomic Grip
- Includes UV Enhancing Safety Glasses.

**PATENT NO. 6,647,761**



## 53413 BATTERY CARTRIDGE (12V/50 WATT)

- This powerful rechargeable battery charger holds a charge equal to 30 minutes of continuous use.



### BATTERY CHARGER

- 53414 110V/60 HZ  
53414-220 220V/50-60 HZ



## ACCESSORIES

**53314 DYE REMOVER** - 4oz (120ml)

**53315 SERVICE LABELS** -

25 per pack, bright yellow label indicating that the system has been charged with UV Dye

**92398 UV ENHANCING SAFETY**

**GLASSES** -

This is a must for protection against ultraviolet light during leak detection.

LIGHT PART#	LIGHT BULB PART#	LENS PART#
53012	53012-B	53012-L
53112	53012-B	53110-L
53312	53312-B	53312-L
53411	53312-B	53312-L
53515	53515-B	-



## 53809 MINI DYE INJECTOR

"Cartridge Type" Dye Injector (10 Applications) Concentrated Dye.



## 53223 "CARTRIDGE TYPE" UNIVERSAL DYE/OIL INJECTOR

Adding dye with the 53223 is fast and easy, simply connect the injector to the low side of the A/C system and twist the handle to the next application line. The replaceable cartridge provides 25 applications of universal dye that is compatible with R12/22/502 and R134a systems. The injector hose comes complete with a R134a coupler and auto shut-off valve adapter for 1/4" FL systems.



## REFILLABLE UNIVERSAL DYE/OIL INJECTOR

To inject the oil or dye, simply connect the injector to the low side of the A/C system and twist the handle until you reach the desired amount. The injector hose comes complete with a R134a coupler and auto shut-off valve adapter for 1/4" FL systems.

### 53123 REFILLABLE UNIVERSAL DYE INJECTOR

with 2 oz Bottle of Concentrated A/C Dye (25 Apps)

### 53123-A REFILLABLE UNIVERSAL DYE/OIL INJECTOR (w/o dye)

### 53134 REFILLABLE DYE INJECTOR

with (R134a 13 mm Connection) and 2 oz Bottle of Concentrated A/C Dye (25 Applications)

### 53322 REFILLABLE DYE INJECTOR

with (1/4" Auto Shut-off Valve Connection) and 2 oz Bottle of Concentrated A/C Dye (25 Apps)

## ULTRAVIOLET DYES

### STANDARD UNIVERSAL A/C DYES

Pack 1/4 oz - 1 Application

**92699 Standard Universal Dye** - Six 1/4 oz Packs (6 pcs)

8 oz Bottle - 32 Applications

**92708 Standard Universal Dye**

32 oz Bottle - 128 Applications

**92732 Standard Universal Dye**

### CONCENTRATED UNIVERSAL DYES

**53825 Universal Dye Cartridge**

Replaceable Cartridge - 25 Applications

**53810 Concentrated Dye Cartridge**

Replaceable Cartridge - 10 Applications

**53625 Universal Dye**

2oz Bottle - 25 Applications



## STANDARD

### 82375

1/2" ACME-M x 1/2" ACME-F (R134a)

### 90375

1/4" FFL x 1/4" MFL



## EASY CONNECT

### 82374

13mm-M x 13mm-F Low-Side Coupler (R134a)

### 92376

1/4" FFL x 1/4" MFL



## FLUORESCENT DYE

**53609 ENGINE COOLANT FLUORESCENT DYE** (1 oz. bottle)

- 1 oz for 1 vehicle application per 16 quarts of fluid

**53610 OIL/AFT/GAS FLUORESCENT DYE** (1 oz. bottle)

- Engine Oil (Gas & Diesel)  
1 vehicle application per 4-5 quarts of oil
- Automatic Transmission Fluid  
1 vehicle application per 4-5 quarts of fluid
- Gasoline & Diesel Fuel  
1 vehicle application per 2 gallons of fuel



## COMPRESSOR OILS

Maximum protection with excellent thermal & oxidative stability. Moisture tolerant. OEM approved.

**53826 PAG 100 OIL** (2 oz cartridge)

**53827 Ester Oil** (2 oz cartridge)

**92709 PAG 100 OIL** (8 oz bottle)

**92710 Ester Oil** (8 oz bottle)

**92711 PAG 100 OIL** (32 oz bottle)

**92712 Ester Oil** (32 oz bottle)



**Mastercool**<sup>®</sup>  
"World Class Quality"

## 55100 ELECTRONIC LEAK DETECTOR

The 55100 offers an accurate and reliable solution to Electronic Leak Detection.

### SPECIFIC FEATURES:

- 3 Levels Of Sensitivity (5 Levels Of Detection)
- Visual Leak Level Indicator
- Detects Leaks As Small As 3 gr (1/10 oz) Per Year
- Detects All Refrigerants, CFC'S, HCFC'S, HFC'S

### 55100-SEN

Sensor Tip for 55100, 55200, 55300 & 55400



**POPULAR**

## Mastercool introduces the "Next Generation" in Electronic Leak Detection!

The 55200 "INSPECTOR" and 55100 offer revolutionary new features and state of the art micro processing technology. The new design sensor delivers an accurate and instantaneous response. Both units come in a heavy duty custom molded carrying case and meet SAE J1627 and CE conformity.

### 55200 / 55100 GENERAL FEATURES / SPECIFICATIONS

- Digital Signal Micro Processor
- Auto Release Feature
- Keypad Control
- Detects All Halogenated Refrigerants
- Battery Test Feature
- Power Supply (2 "C" Batteries)
- Meets SAE J1627 / CE Conformity
- Flexible 16" Probe
- Variable Frequency Audible Alarm
- Includes Custom Molded Carrying Case

## 55200 "INSPECTOR" 2 IN 1 ELECTRONIC / UV LEAK DETECTOR

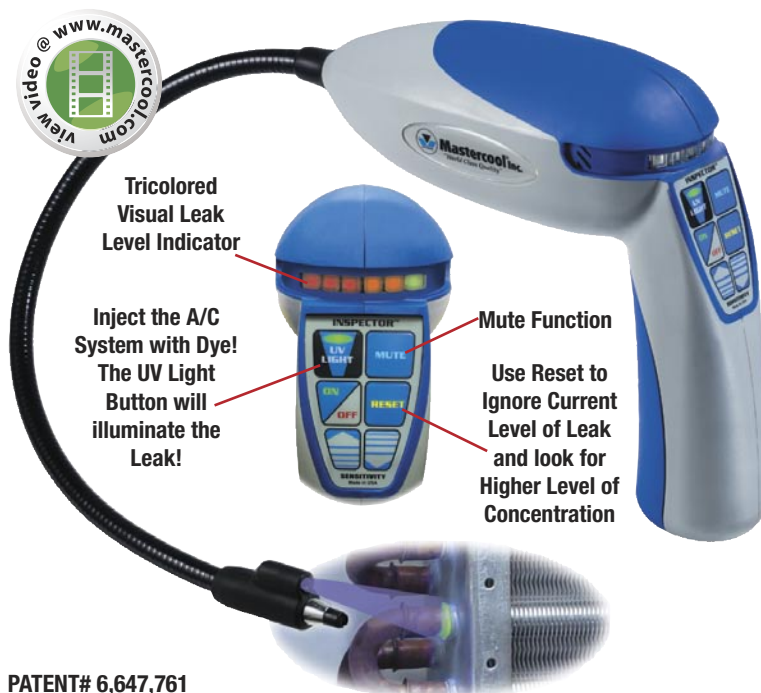

Tricolored Visual Leak Level Indicator

Inject the A/C System with Dye! The UV Light Button will illuminate the Leak!

Mute Function

Use Reset to Ignore Current Level of Leak and look for Higher Level of Concentration

PATENT# 6,647,761

This revolutionary new design allows the user to perform Electronic and UV Leak Detection all with one tool. The "INSPECTOR" offers six levels of sensitivity (15 levels of detection) with a tri-colored LED indicator. This allows the "INSPECTOR" to pin-point leaks as small as 1/10 oz per year. The ultra bright UV light is built into the end of the probe allowing easy access into tight areas. Incorporating both electronic and UV technology into one unit insures that even the toughest leaks can be found.

### SPECIFIC FEATURES

- 6 Levels Of Sensitivity (15 Levels Of Detection)
- Detects Leaks As Small As 1/10 oz Per Year
- Detects All Refrigerants, CFC'S, HCFC'S, HFC'S
- Ultra Bright UV/Blue LED Light
- UV Safety Glasses
- Tricolored Visual Leak Level Indicator
- Mute Function

### 53515-B

LED Bulb for 55200, 55300 & 55400



**POPULAR**

## 55310 COMPLETE ELECTRONIC & UV LEAK DETECTION KIT

This kit offers the "INSPECTOR" along with our UV Dye Injection System. Our cartridge type dye injector is fast and easy to use. Just twist the handle to inject the appropriate amount of dye. The 55310 kit is the ultimate solution for all your A/C leak detection needs.

### SPECIFIC FEATURES

- 55200 "INSPECTOR" Electronic Leak Detector
- UV Dye Injector W/10 Application Dye Cartridge
- Dye Injector Connection Hose W/R12 Adapter
- Dye Cleaner & UV Safety Glasses
- Comes In A Custom Molded Carrying Case

### 55300 - Same as 55310

(with 25 application Dye Cartridge)



## 55400 COMPLETE ELECTRONIC & UV LEAK DETECTION KIT

This kit offers the "INSPECTOR" along with our UV Dye Injection System. Our refillable dye injector is fast and easy to use. Just twist the handle to inject the appropriate amount of dye. The 55400 kit is the ultimate solution for all your A/C leak detection needs.

### SPECIFIC FEATURES

- 55200 "INSPECTOR" Electronic Leak Detector
- Refillable Dye Injector
- Dye Injector Connection Hose W/R12 Adapter
- 2 oz Bottle of Concentrated Universal Dye
- UV Safety Glasses & Dye Cleaner
- Comes In A Custom Molded Carrying Case



## ELECTRONIC LEAK DETECTOR W/HEATED SENSOR

Mastercool broadens it's line by introducing it's Heated Sensor Electronic Leak Detector. The HEATED SENSOR technology delivers fast and accurate results while eliminating non-refrigerant false alarms. The flexible 15" probe has a patented UV Blue Light built into the tip allowing dual UV and Electronic Leak Detection.

**55500** Electronic Leak Detector W/110V Battery Charger

**55500-220** Electronic Leak Detector W/220V Battery Charger

### SPECIFICATIONS:

- Operating Temp: 32-125°F
- Power Supply: 2 C-Size 1.5V Ni-MH Battery
- Battery Life: 8 hrs per cycle (1000 cycles)
- Warm-Up Time: 25 Seconds
- Probe/Core Length: 15"
- Dimension: 7 x 7"
- Weight: 1.10 lbs
- Ultimate Sensitivity: 1/10 oz per year

### FEATURES:

- Six Sensitivity Levels
- Automatic Warm Up
- Reset Function
- Dual-colored Visual LED Leak Size Display
- Blue UV LED Light
- Rechargeable Ni-MH Battery
- Low Battery Indicator
- High Volume Pump
- Meets and Exceeds SAE J1627
- 3 Year Limited Warranty
- Detects all Refrigerants (CFC's, HCFC's, HFC's)
- Made in USA

Part#	Description
<b>53515-B</b>	LED Bulb for 55500
<b>55500-SEN</b>	Replacement Sensor



PATENT# 6,647,761

## COMBUSTIBLE GAS LEAK DETECTOR

Mastercool introduces it's hand-held combustible gas leak detectors. Offering the most advanced sensor technology with a state-of-the-art microprocessor, these units detect leaks fast and accurately. The flexible 15" probe has a bright LED light built into the tip for easy viewing in hard to reach locations. The membrane switch panel offers easy one touch control and operation. Each of the six levels of sensitivity has an audible alarm and visual indicator to identify leak activity. These units include the newest rechargeable Ni-MH battery (nearly double the power of existing Ni-Cad batteries) and comes in a custom molded case.

**55750** Combustible Gas Leak Detector W/110V Battery Charger

**55750-220** Combustible Gas Leak Detector W/220V Battery Charger

### SPECIFICATIONS:

- Operating Temp: 32-125°F
- Power Supply: 2 C-Size 1.5V Ni-MH Battery
- Battery Life: 8 hrs per cycle (1000 cycles)
- Warm-Up Time: 25 seconds
- Probe/Core Length: 15"
- Dimension: 7 X 7"
- Weight: 1.10 lbs
- Ultimate Sensitivity: 50 – 1000 ppm

### FEATURES:

- Six Sensitivity Levels
- Reset Function
- Automatic Warm Up
- Bright LED Light
- Audible Leak Alarm & Visual Leak Size Indicator
- Rechargeable Ni-MH Battery
- Low Battery Indicator
- Custom Molded Carrying Case
- Made in USA



### DETECTS:

Acetone, Acetylene, Ammonia, Benzene, Butane, Butanol, Chlorine, Ethane, Ethanol, Gasoline, Hexane, Hydrogen, Hydrogen Sulfide, Isobutane, Methane (natural gas), Methanol, Methyl Acetate, Methyl Chloride, Methyl Ether, Naptha, N-Butane, Pentane, Propane, Propanol, Sulfur Dioxide and Trichloroethane

PATENT# 6,647,761



**Mastercool**<sup>®</sup>  
"World Class Quality"

## 52224-A INFRARED THERMOMETER W/LASER

Temperature Range: -58°F to 932°F (-50°C to 500°C)

Field of View: 12 : 1

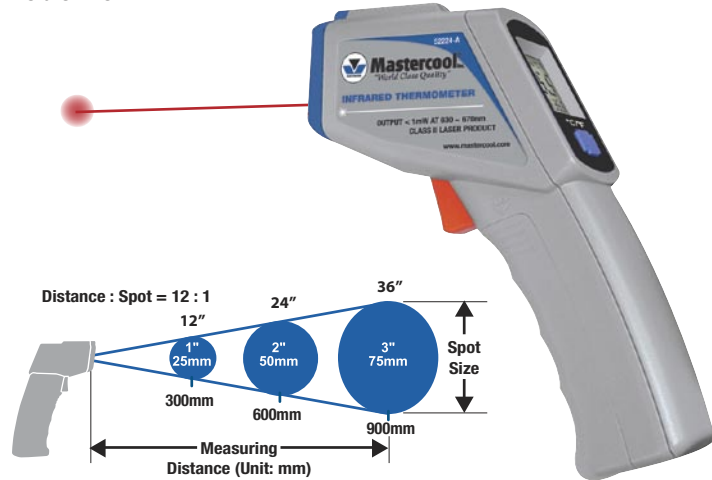

The 52224-A offers laser targeting accuracy, enhanced back-lit LCD Display and an expanded temperature range. The compact design is simple to use and easy to store.

### SPECIFICATIONS:

<b>Non-Contact Temp. Range:</b>	-58 to 932°F (-50 to 500°C)
<b>Field of View:</b>	12 : 1
<b>Display Illumination:</b>	Backlit LCD display
<b>Target Indicator:</b>	Single Laser Spot
<b>Emissivity:</b>	0.98
<b>Resolution:</b>	0.5°F / 0.5°C
<b>Accuracy:</b>	4°F (±2°C) or ±2% of reading
<b>Response Time:</b>	0.5 seconds
<b>Power Off:</b>	Automatic after 15 seconds
<b>Battery Life:</b>	Approx. 180 hrs.
<b>Included Accessories:</b>	2 AAA batteries, instruction manual, plastic case



## 52224-C INFRARED THERMOMETER W/DUAL LASER

Temperature Range: -58°F to 932°F (-50°C to 500°C)

Field of View: 12 : 1



The Mastercool 52224-C accurately hits your target with dual laser technology. It features an enhanced back-lit LCD Display and an expanded temperature range of -58°F to 932°F (-50°C to 500°C). The compact design is simple to use and easy to store.

### SPECIFICATIONS:

<b>Non-Contact Temp. Range:</b>	-58 to 932°F (-50 to 500°C)
<b>Field of View:</b>	12 : 1
<b>Display Illumination:</b>	Backlit LCD display
<b>Target Indicator:</b>	Dual Laser Spot
<b>Emissivity:</b>	0.98
<b>Resolution:</b>	0.5°F / 0.5°C
<b>Accuracy:</b>	4°F (±2°C) or ±2% of reading
<b>Response Time:</b>	0.5 seconds
<b>Power Off:</b>	Automatic after 15 seconds
<b>Battery Life:</b>	Approx. 180 hrs.
<b>Included Accessories:</b>	2 AAA batteries, instruction manual, plastic case



## 52225-A DUAL TEMP PLUS INFRARED THERMOMETER

Non-Contact Temperature Range: -76 to 1400°F (-60 to 760°C)

Field of View: 30 : 1



Features both infrared and contact thermometer technologies. Includes programmable HI/LO alarms and Lock Mode to capture temperature readings. The contact function offers a built-in K type jack and wire thermocouple.

### SPECIFICATIONS:

<b>Non-Contact Temp. Range:</b>	-76 to 1400°F (-60 to 760°C)
<b>Thermocouple Temp. Range:</b>	-83 to 1999°F (-64 to 1400°C)
<b>Field of View:</b>	30 : 1
<b>Display Illumination:</b>	Backlit LCD display
<b>Target Indicator:</b>	Single Laser Spot
<b>Emissivity:</b>	0.10(10E) to 1.0 (100E)
<b>Resolution:</b>	0.1°F / 0.1°C
<b>Modes:</b>	MIN, MAX, DIFF & AVG
<b>Accuracy:</b>	±2% of reading
<b>Response Time:</b>	1 second
<b>Power Off:</b>	Automatic after 60 seconds
<b>Battery Life:</b>	Approx. 180 hrs.
<b>Included Accessories:</b>	2 AAA batteries, 3 ft thermocouple probe, instruction manual, plastic case
<b>Optional Accessories:</b>	10ft Wire Thermocouple Probe, Piercing Penetration Probe, Surface Probe, Air Probe



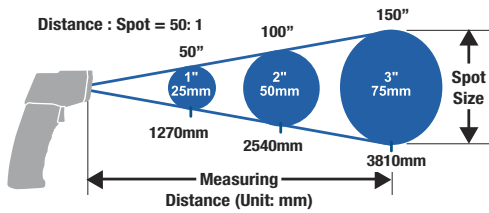

## 52225-B ULTRA TEMP DUAL LASER THERMOMETER

**Non-Contact Temperature Range: -76 to 1832°F (-60 to 1000°C)**

**Field of View: 50 : 1**

Features both infrared and contact thermometer technologies. Includes programmable HI/LO alarms, and Lock Mode to capture temperature readings. The built-in K type jack offers optional contact functions. Illuminates working area with built-in LED light.

### SPECIFICATIONS:

<b>Non-Contact Temp. Range:</b>	-76 to 1832°F (-60 to 1000°C)
<b>Thermocouple Temp. Range:</b>	-83 to 1999°F (-64 to 1400°C)
<b>Field of View:</b>	50 : 1
<b>Display Illumination:</b>	Backlit LCD display
<b>Target Indicator:</b>	Dual Laser Spot
<b>Emissivity:</b>	0.95
<b>Resolution:</b>	0.1°C / 0.1°F
<b>Modes:</b>	MIN, MAX, DIFF & AVG
<b>Accuracy:</b>	±2% of reading
<b>Response Time:</b>	1 second
<b>Power Off:</b>	Automatic after 60 seconds
<b>Battery Life:</b>	Approx. 180 hrs.
<b>Included Accessories:</b>	2 AAA batteries, instruction manual, plastic case
<b>Optional Accessories:</b>	3ft, 10ft Wire Thermocouple Probes, Piercing Penetration Probe, Surface Probe, Air Probe, Removable Magnetic Base



All thermometers include pocket holder and clip.

### POCKET ANALOG DESIGNS

Item#	Dial Size	Temperature Scale
52220	1"	0 to 220°F
52161	1 3/8"	-40 to 160°F
91120	1 3/4"	0 to 220°F

### POCKET DIGITAL DESIGN

Item#	Dial Size	Temperature Scale
52223-A	1"	-58 to 302°F

Battery operated (1.5V, life of 5000 hours), on/off and auto shut-off after 10 minutes.



### 52226

#### DUAL TEMP INFRARED/PROBE THERMOMETER

The 52226 Dual Temp Thermometer offers both infrared and contact probe technologies.

- Infrared Temp Range: -67 to 428°F (-55 to 220°C)
- Probe Temp Range: -67 to 626°F (-55 to 330°C)
- Field of View Ratio 1 : 1
- Adjustable Emissivity
- Lock Mode for hands free scanning
- Minimum / Maximum capture mode
- Contact Probe locks safely on the side of the unit



### 52227

#### POCKET INFRARED THERMOMETER

The 52227 Pocket Infrared Thermometer offers accurate non-contact temperature measurement in a compact and easy to use size.

- Temp Range: -67 to 428°F
- Field of View Ratio 1 : 1
- Adjustable Emissivity
- Backlit LCD Display
- Minimum/Maximum capture mode
- Lithium Battery



### OPTIONAL PROBES

- 52331 Wire Thermocouple Probe - 3ft (1m)
- 52332 Wire Thermocouple Probe - 10ft (3m)
- 52333 Piercing Penetration Probe
- 52334 Surface Probe
- 52335 Air Probe

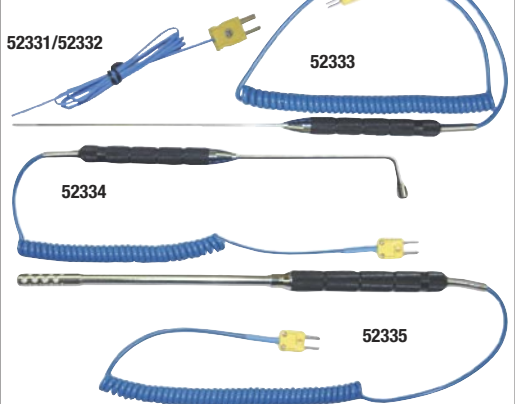

**Mastercool®**  
"World Class Quality"

**POPULAR**



Fabricating A/C Hoses Just Got Easier With The...

## 71500 HYDRA-KRIMP

Mastercool's Patented "Hydra - Krimp" makes crimping barbed and beaded fittings as easy as 1 - 2 - 3! The lightweight hand-held hydraulic press is very portable and ideal for shop and field applications. The kit comes with a complete set of dies covering hose sizes #6, #8, #10, #12 and reduced barrier #6, #8, #10 and #12. The dies snap quickly into the press fixture requiring no pins or screws. Kit comes in a custom molded case and includes:

Part#	Description
71500 - 001A	Hydra - Krimp Pump
71500 - 001B	Hydra - Krimp Yoke
71500-001C	Complete Die Set Assembly (7 pc. set)
71500 - 6	Die Set - #6 (5/16") Die Set - #8 (13/32" Reduced Barrier)
71500 - 8	Die Set - #8 (13/32")
71500 - 10	Die Set - #10 (1/2")
71500 - 12	Die Set - #12 (5/8")
71500 - 6SRB	Die Set - #6 (5/16" Reduced Barrier)
71500 - 10SRB	Die Set - #10 (1/2" Reduced Barrier)
71500 - 12SRB	Die Set - #12 (5/8" Reduced Barrier)
71500 - PB	Custom Molded Box

PATENT# 6,324,884

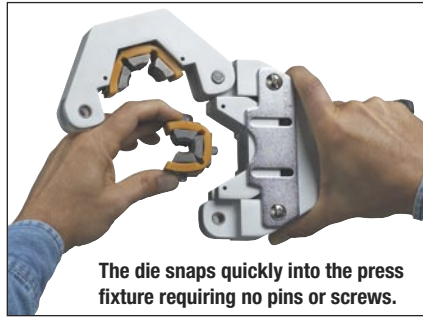

The die snaps quickly into the press fixture requiring no pins or screws.

**POPULAR**



## 71550 A/C HOSE CRIMPER

The 71550 is our "manual style" A/C hose crimper. The dies snap quickly into place requiring no pins or screws. The unit can be easily mounted to a bench using the holding fixture or held securely in a vice. This kit comes with a complete set of dies covering standard hose sizes #6, #8, #10 and #12. \*Optional reduced barrier sizes are available.

Part#	Description
71550 - 001	Yoke Assembly
71550 - 002	Arbor Assembly
71550 - 003	Holding Fixture Assembly
71500 - 6	Die Set - #6 (5/16")
71500 - 8	Die Set - #8 (13/32")
71500 - 10	Die Set - #10 (1/2")
71500 - 12	Die Set - #12 (5/8")
71550 - PB	Custom Molded Carrying Case

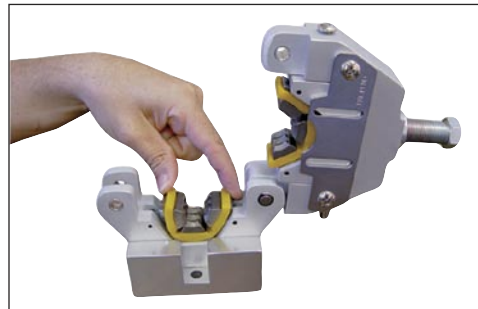

The die snaps quickly into the press fixture requiring no pins or screws.

PATENT# 6,324,884



POPULAR

**71475 UNIVERSAL HYDRAULIC FLARING TOOL SET**

This kit fabricates Push Connect 1/4, 5/16 and 3/8"; GM Fuel Line Flare, Brake Lines and Transmission 5/16 and 3/8"; Flare/Double Flare 3/16, 1/4, 5/16, 3/8 and 1/2"; Metric Bubble Flare 4.75, 6, 8, and 10mm. Comes in a custom molded box.

<b>71201</b>	Hydra-flare Yoke & Pump Assembly	<b>71097-01</b>	45° Flaring Cone
<b>Push-Connect Adapters</b>		<b>Push-Connect Die Sets</b>	
<b>71204</b>	1/4" Adapter	<b>71214</b>	1/4" Die Set
<b>71205</b>	5/16" Adapter	<b>71215</b>	5/16" Die Set
<b>71206</b>	3/8" Adapter	<b>71216</b>	3/8" Die Set
<b>GM Fuel Line Adapters</b>		<b>GM Fuel Line Die Sets</b>	
<b>71405</b>	5/16" Adapter	<b>71415</b>	5/16" Die Set
<b>71406</b>	3/8" Adapter	<b>71416</b>	3/8" Die Set
<b>45° &amp; Double Flaring Adapters</b>		<b>45° &amp; Double Flaring Die Sets</b>	
<b>71097-03</b>	3/16" Adapter	<b>71097-13</b>	3/16" Die Set
<b>71097-04</b>	1/4" Adapter	<b>71097-14</b>	1/4" Die Set
<b>71097-05</b>	5/16" Adapter	<b>71097-15</b>	5/16" Die Set
<b>71097-06</b>	3/8" Adapter	<b>71097-16</b>	3/8" Die Set
<b>71097-08</b>	1/2" Adapter	<b>71097-18</b>	1/2" Die Set
<b>Metric Bubble Flaring Adapters</b>		<b>Metric Bubble Flaring Die Sets</b>	
<b>71475-4M</b>	4.75mm Adapter	<b>71475-14M</b>	4.75mm Die Set
<b>71475-6M</b>	6mm Adapter	<b>71475-16M</b>	6mm Die Set
<b>71475-8M</b>	8mm Adapter	<b>71475-18M</b>	8mm Die Set
<b>71475-10M</b>	10mm Adapter	<b>71475-110M</b>	10mm Die Set
<b>71475-PB</b>	Custom Molded Plastic Box for 71475		



**71400 GM FUEL LINE FLARING KIT**

This kit fabricates the special flares found on most GM fuel lines and some GM truck power steering pump return lines (5/16"). Kit comes in a custom molded carrying case and includes:

<b>71201</b>	Hydra-flare Yoke & Pump Assembly
<b>GM Fuel Line Adapters and Die Sets:</b>	
<b>71405</b>	5/16" Adapter
<b>71415</b>	5/16" Die Set
<b>71406</b>	3/8" Adapter
<b>71416</b>	3/8" Die Set
<b>71200-PB</b>	Custom Molded Carrying Case



**71450 DOUBLE FLARE & METRIC BUBBLE FLARING TOOL SET**

This kit fabricates flare/double flare 3/16, 1/4, 5/16, 3/8 and 1/2"; and metric bubble flare 4.75, 6, 8 and 10mm. Comes in a custom molded carrying case and includes:

<b>71201</b>	Hydra-flare Yoke & Pump Assembly	<b>71097-01</b>	45° Flaring Cone
<b>45° &amp; Double Flaring Adapters and Die Sets:</b>		<b>Metric Bubble Flaring Adapters and Die Sets:</b>	
<b>71097-03</b>	3/16" Adapter	<b>71097-13</b>	3/16" Die Set
<b>71097-04</b>	1/4" Adapter	<b>71097-14</b>	1/4" Die Set
<b>71097-05</b>	5/16" Adapter	<b>71097-15</b>	5/16" Die Set
<b>71097-06</b>	3/8" Adapter	<b>71097-16</b>	3/8" Die Set
<b>71097-08</b>	1/2" Adapter	<b>71097-18</b>	1/2" Die Set
<b>71475-4M</b>	4.75mm Adapter	<b>71475-14M</b>	4.75mm Die Set
<b>71475-6M</b>	6mm Adapter	<b>71475-16M</b>	6mm Die Set
<b>71475-8M</b>	8mm Adapter	<b>71475-18M</b>	8mm Die Set
<b>71475-10M</b>	10mm Adapter	<b>71475-110M</b>	10mm Die Set
<b>71450-PB</b>	Custom Molded Carrying Case		



**Mastercool**<sup>®</sup>  
"World Class Quality"



## 71480 37° FLARING AND DOUBLE FLARING HYDRAULIC TOOL KIT

This kit fabricates factory style 37° and 37° double flare found on aviation and specialty automotive applications. The handheld hydraulic pump operates easily with all steel and light stainless tubing.

Includes: 3/16, 1/4, 5/16, 3/8 and 1/2" dies 3/16, 1/4, 5/16, 3/8 and 1/2" double flare adapters and 37° Cone

<b>71201</b>	Hydra-flare Yoke & Pump Assembly	<b>71098-01</b>	37° Cone
<b>37° Double Flaring Adapters &amp; Die Sets</b>			
<b>71098-03</b>	3/16" Double Flare Adapter	<b>71098-13</b>	3/16" Double Flare Die Set
<b>71097-04</b>	1/4" Double Flare Adapter	<b>71098-14</b>	1/4" Double Flare Die Set
<b>71097-05</b>	5/16" Double Flare Adapter	<b>71098-15</b>	5/16" Double Flare Die Set
<b>71097-06</b>	3/8" Double Flare Adapter	<b>71098-16</b>	3/8" Double Flare Die Set
<b>71097-08</b>	1/2" Double Flare Adapter	<b>71098-18</b>	1/2" Double Flare Die Set

## 71098 37° FLARING & DOUBLE FLARING ADAPTER SET

- Dies: 3/16, 1/4, 5/16, 3/8 and 1/2"
- Double Flare Adapters: 3/16, 1/4, 5/16, 3/8 and 1/2"
- 37° Cone



## 71300 PUSH-CONNECT, 45° & DOUBLE FLARING SET WITH "HYDRA-FLARE"

Fabricates "production quality" flares quickly and easily with hand held convenience. Flaring die sets for five sizes: 3/16, 1/4, 5/16, 3/8 and 1/2" O.D. tubing; five double flaring adapters cover 3/16, 1/4, 5/16, 3/8 and 1/2" O.D. tubing. Set includes:

<b>71201</b>	Hydra-flare Yoke & Pump Assembly	<b>71097-01</b>	45° Flaring Cone
<b>Push-Connect Adapters and Die Sets:</b>			
<b>71204</b>	1/4" Adapter	<b>71214</b>	1/4" Die Set
<b>71205</b>	5/16" Adapter	<b>71215</b>	5/16" Die Set
<b>71206</b>	3/8" Adapter	<b>71216</b>	3/8" Die Set
<b>45° &amp; Double Flaring Adapters and Die Sets:</b>			
<b>71097-03</b>	3/16" Adapter	<b>71097-13</b>	3/16" Die Set
<b>71097-04</b>	1/4" Adapter	<b>71097-14</b>	1/4" Die Set
<b>71097-05</b>	5/16" Adapter	<b>71097-15</b>	5/16" Die Set
<b>71097-06</b>	3/8" Adapter	<b>71097-16</b>	3/8" Die Set
<b>71097-08</b>	1/2" Adapter	<b>71097-18</b>	1/2" Die Set



Push Connect



45° Double Flare

## 70092 45° FLARING, DOUBLE FLARING & CUTTING TOOL SET



45° Double Flare



Includes heavy duty tube cutter **70033** for 1/8 to 1 1/8" O.D. tubing; standard 45° flaring tool **70051** flares 7 sizes: 3/16, 1/4, 5/16, 3/8, 7/16, 1/2 and 5/8" O.D. tubing; five double flaring adapters **70192** cover 3/16, 1/4, 5/16, 3/8 and 1/2" O.D. tubing.

Also available:

**70097** Same as 70092, less 70033 tube cutter

**70192** Set of 5 double flaring adapters for 3/16, 1/4, 5/16, 3/8 and 1/2" O.D. tubing.

**70092-M** Metric Flaring, Double Flaring & Cutting Tool Set  
Flares 7 metric sizes: 4, 6, 8, 10, 12, 15 and 16mm O.D. tubing.

**70192-M** Metric Double Flaring Adapter Set Covers 4.75, 5, 6, 8 and 10mm O.D. tubing.

**70097-M** Same as 70092-M, less 70033 tube cutter.

## 71100 METRIC BUBBLE FLARING TOOL SET



Metric Bubble Flare

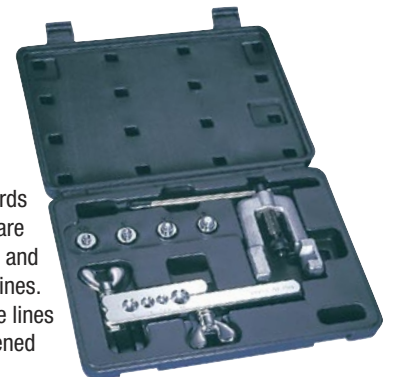

Fashions International Standards Organization (I.S.O.) bubble flare found on European, Japanese and some domestic model brake lines. Flares without removing brake lines from a vehicle. Includes hardened steel bar and carrying case.

Set includes: Adapters for 4.75, 6, 8 and 10mm O.D. tubing.

Also available:

**71101** Set of four bubble flaring adapters for 4.75, 6, 8 and 10mm O.D. tubing.

**BALL BEARING CUTTERS**

Mastercool's New EZ Tube Cutters offer the latest "Reduced Friction" technology! Our new reduced friction design incorporates ball bearings into the cutter wheel, tube rollers and a control knob. Reducing the resistance in these high friction areas allows the cutter to roll fast and easy as it slices through the tube. The new "Reduced Friction" design is sure to save time and reduce fatigue!

- 72029 "REDUCED FRICTION" TUBE CUTTER for 1/8 to 1 1/8" (3-28mm)
- 72035 "REDUCED FRICTION" TUBE CUTTER for 1/4 to 1 1/2" (6-38mm)
- 72030 REPLACEMENT CUTTING WHEEL for 72029
- 72034 REPLACEMENT CUTTING WHEEL for 72035

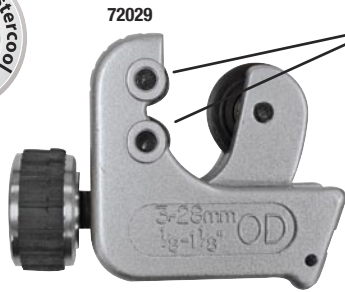

Each cutter includes up to 8 ball bearings for easy operation and extra smooth cut.



Includes a detachable swivel deburring tool for smooth surface



Standard steel cutting wheel used on competing cutters

Re-enforced steel cutting wheel with internal ball bearings for extra smooth cut

**TUBE CUTTERS**

MASTERCOOL tube cutters are lightweight yet durable. Carbide steel cutting wheels work with hard and soft copper, aluminum, brass, thin wall steel and stainless steel. All cutters feature rollers with flare cut-off grooves to salvage as much old tubing material as possible.

- 70027 MINI TUBE CUTTER for 1/8 to 5/8" O.D. Tubing (1/8 to 1/2" Nominal).
- 70029 MINI TUBE CUTTER for 3/8 to 1 1/8" O.D. Tubing (1/4 to 1" Nominal).
- 70033 HEAVY DUTY TUBE CUTTER for 1/8 to 1 1/8" O.D. Tubing (1/4 to 1" Nominal).
- 70035 HEAVY DUTY TUBE CUTTER for 1/4 to 1 5/8" (1/4 to 1 1/2" Nominal).
- 70037 SLIDING RATCHET TUBE CUTTER for 1/4 to 2 5/8" O.D. Tubing (1/4 to 2 3/4" Nominal), Triple Chrome Plated.
- 70038 SLIDING RATCHET TUBE CUTTER for 1/4 to 3 1/2" O.D. Tubing (1/4 to 1 1/2" Nominal).



70027



70033



70029



70037

**REPLACEMENT CUTTER WHEELS**

- 70028 Replacement Cutting Wheels for 70027 (10 pcs).
- 70034 Replacement Cutting Wheels for 70029, 70033, 70035 and 70037 (10 pcs + 1 holding screw).
- 70128 Carbide Cutting Wheel & Screw Set for 70027 includes: 2 Spare Cutting Wheels and 1 Holding Screw.
- 70134 Carbide Cutting Wheel and Screw Set for 70029, 70035, and 70037. Includes: 2 Spare Cutting Wheels and 1 Holding Screw.
- 70138 Replacement Cutting Wheel for 70038 (1 per pkg.) Cut Hard and Soft Copper, Aluminum, Brass, Thin Wall Steel and Stainless Steel.
- 70237 PVC Cutting Wheel for 70037. Cuts PVC and ABS.
- 70238 Oversize PVC Cutting Wheel for 70038. Wheel is 1 5/8" Diameter. Cuts PVC and ABS.

**TUBE CONSTRICTOR WHEEL**

- 70233 Used with 70033 or 70035.



**Mastercool**<sup>®</sup>  
"World Class Quality"



## RATCHET STYLE TUBE CUTTER

- 70030** When you don't have swing room, ratchet action allows cutting all the way around the tubing easy (1/4 to 7/8" O.D. Tubing)
- 70031** (5/16 to 1 1/8" O.D. Tubing)



## 80021 PLUMBERS TYPE MINI CUTTER

- Designed for applications with limited working space. Cuts soft copper, aluminum and thin wall steel tubing. Tube Cutter for 1/8 to 7/8" (4-22mm) O.D. Tubing. (1/8 to 3/4" nom.)
- 80121** Spare Cutting Wheel for 80021

## INNER-OUTER REAMERS



- 70085** Inner/Outer Reamer for 3/16 to 1 1/2" O.D. Tubing.



- 71685** Designed to remove inner burrs easily. Full metal grip. Includes one spare tungsten blade for long use.
- 71686-2** Two spare blades for 71685 (2 pcs).



## 70069-A 4-IN-1 LEVER STYLE TUBE BENDER

Complete 180° bend all metal multi-purpose tube bender for 3/16, 1/4, 5/16 and 3/8" O.D. Tubing.

## SPRING STYLE TUBE BENDERS

Economical and effective tools for bending soft copper or aluminum tubing without kinks. Special nickel plated, spring steel is flared on one end for quick tube insertion. Each tool bends one size.

MODEL#	SIZE	LENGTH
70071	1/4"	10"
70072	5/16"	10"
70073	3/8"	10"
70074	1/2"	12"
70075	5/8"	14"
70077	3/4"	14"



## 70076 SPRING STYLE TUBE BENDER SET

Set of 5 spring benders for 1/4, 5/16, 3/8, 1/2 and 5/8" O.D. tubing.



## RATCHET WRENCHES

- 70081** Steel forged wrench with reversible ratchet. 9/16", 1/2" hex, 1/4" and 3/16" square.
- 70082** Compact chrome plated wrench specially designed for use in hard to reach places. 1/4, 3/8, 3/16 and 5/16" square ratchet.

## 91274 MASTER CLUTCH SERVICE TOOL SET

The Set contains all the tools needed to service clutches on the following compressors: General Motors A6, R4, and DA6; 6 Pole R4, V5 and HR-6; Ford FS6; Chrysler C171; Nippondenso 6P 148A; Sanden 507, 508 and 510 and Pitts and Warner clutches.

Contains:

<b>90291</b> Coil Puller Jaws	<b>91012</b> Shaft Protector Pilot
<b>90292</b> Coil Installer	<b>91022</b> Rotor & Bearing Puller Jaws
<b>90343</b> Compressor Holding Fixture & Hardware	<b>91023</b> Rotor & Bearing Puller Arbor
<b>90346</b> Rotor & Bearing Pilot	<b>91047</b> Tool Box
<b>90349</b> Clutch Assembly Installer	<b>91058</b> Pulley Remover Jaws
<b>90443</b> Pulley Bearing Remover & Driver	<b>91059</b> Bearing & Pulley Installer
<b>90451</b> Pulley Arbor	<b>91146</b> Feeler Gauge Set
<b>90452</b> Pulley Removal Jaws	<b>91183</b> A/C Service Manual
<b>90455</b> Pulley Removal Pilot	<b>91216</b> Coil Installer Tie Bolt Set
<b>90456</b> Pulley Hub Removal Pilot	<b>91218</b> GM Compressor Test Plate
<b>90457</b> Puller Body	<b>91261</b> Holding Fixture and Hardware
<b>90903</b> External Retaining Ring Pliers	<b>92210</b> Clutch Bearing Staking Tool

**All tools available individually.**

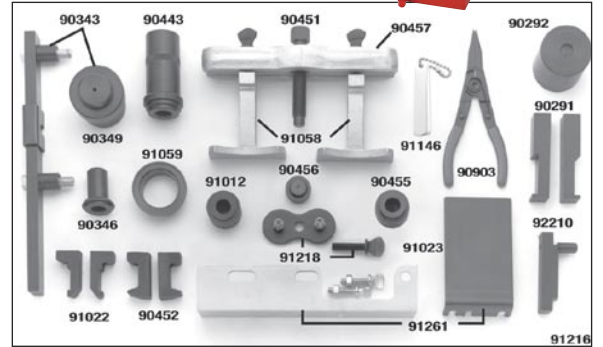

## 91268 MASTER SEAL SERVICE TOOL SET

The set includes all the tools from 91269, 91270, 91271, 91272 and 91273 in a rugged metal tool box. Easy to understand instruction manual will show you step-by-step how to service all the popular compressors.

Contains:

<b>90383</b> Internal Snap Ring Pliers	<b>90906</b> Seal Remover & Installer
<b>90412</b> O-Ring Seal Sleeve Remover	<b>90907</b> Seal Protector Sleeve
<b>90414</b> Seal Seat Remover	<b>90910</b> Clutch Plate Installer
<b>90415</b> Seal Remover & Installer	<b>91047</b> Tool Box
<b>90431</b> York & Tecumseh Oil Level Dipstick	<b>91052</b> Clutch Plate Installer
<b>90432</b> Chrysler Oil Level Dipstick	<b>91060</b> Seal Seat Remover
<b>90440</b> 5/8" x 2" x 11 NC Clutch Remover	<b>91061</b> Seal Seat Installer
<b>90441</b> 5/8" x 2" x 18 SAE Clutch Remover	<b>91122</b> Clutch Plate Remover
<b>90454</b> Clutch Plate Remover	<b>91183</b> A/C Service Manual
<b>90458</b> Clutch Plate Installer	<b>91195</b> Clutch Plate Remover Arbor
<b>90460</b> O-Ring Installation Guide	<b>91202</b> O-Ring Installation Guide
<b>90462</b> Seal Seat Installer	<b>91208</b> Seal Remover & Installer
<b>90473</b> Seal Remover	<b>91211</b> Shaft Protector
<b>90474</b> Seal Installer & Plate Alignment	<b>91212</b> Clutch Plate Remover
<b>90484</b> Seal Protector	<b>91213</b> Clutch Plate Installer
<b>90486</b> Ceramic Seal Seat Remover & Installer	<b>91214</b> O-Ring & Snap-Ring Installer
<b>90499</b> Universal Clutch Holding Tool	<b>91215</b> O-Ring Installation Guide
<b>90902</b> Clutch Plate Puller	<b>All tools available individually.</b>



## 91267 MASTER SEAL & CLUTCH SERVICE TOOL SET

The set includes all Seal Service Tools contained in 91268 and Clutch Service Tools contained in 91274. Tools are stored in a sturdy tool chest (92275) and organized in two drawers with a chart showing which tools are used for a specific compressor. The top part of the tool chest serves as a storage area for fittings and air conditioning test equipment. Space is reserved in the third drawer for an optional Foreign Compressor Seal and Clutch Service Tool Set (91323).



## 91323 IMPORT SEAL & CLUTCH SERVICE TOOL SET

Designed to be included with tool set 91267. When used with tools in the 91267 Master Clutch & Seal set, will service the following compressors:

<b>Diesel Kiki -</b>	DKS-12B & DKS-15B; 13S, 15S, 17S	<b>90396</b>	Ogura/York 6" Clutch Bearing Installer	<b>91106</b>	Ogura Seal Remover/Installer
<b>Ford -</b>	FX-15 / FS-10	<b>90901</b>	Ogura/Sankyo Clutch Holding Tool	<b>91134</b>	Diesel Kiki Clutch Puller Thrust Pin
<b>Hitachi -</b>	C-3817; MJS-130, MJS-157, MJS-170, MJ-123, MJ-167, WP-123, SWP-167	<b>90905</b>	Sanden Seal Seat Remover & Installer	<b>91135</b>	Diesel Kiki Snap-Ring, O-Ring, Felt Installer
<b>Mitsubishi -</b>	SA430, SA439	<b>90916</b>	Sanden Oil Level Dipstick	<b>91137</b>	Diesel Kiki Pulley Pilot
<b>Nippondenso -</b>	6P-148A, 10P-13A, 10P-15C	<b>90917</b>	Sanden Clutch & Pulley Removal Jaws	<b>91138</b>	Diesel Kiki Seal Remover/Installer
<b>Ogura -</b>	OW-100, OW-135	<b>90922</b>	Sanden Pilot Studs	<b>91139</b>	Diesel Kiki Seal Seat Remover/Installer
<b>Sanden -</b>	SD 505, SD 507, SD 508, SD 510, SD 575	<b>90926</b>	Sanden Clutch Installer Pilot	<b>91171</b>	Mitsubishi Seal Seat Remover Lock Sleeve
<b>Seiko-Seiki -</b>	SS 808S	<b>91043</b>	Diesel Kiki Valve Plate Remover	<b>91190</b>	Mitsubishi Pulley Puller Pilot
<b>Tecumseh -</b>	HR-980	<b>91044</b>	Diesel Kiki Lock Nut Remover & Installer	<b>91289</b>	Diesel Kiki Seal Protector
Contains:		<b>91045</b>	Diesel Kiki Drive Plate Remover	<b>91316</b>	Diesel Kiki Clutch Plate Puller
<b>90311</b>	Tecumseh HR-980 Clutch Pulley Retaining Nut Remover/Installer	<b>91073</b>	Sanden 505 Seal Seat Remover & Installer	<b>91326</b>	FX-15 / FS-10 Shaft Seal Remover
<b>90312</b>	Tecumseh HR-980 Dust Cap Remover	<b>91074</b>	Sanden 505 Bearing & Pulley Installer	<b>91327</b>	FX-15 / FS-10 Shaft Seal Installer
<b>90385</b>	York Seal Remover & Installer	<b>91075</b>	Sanden 505 Seal Protector Sleeve	<b>91328</b>	FX-15 / FS-10 Seal Protector
<b>90390</b>	Ogura/York Bearing Driver	<b>91076</b>	Sanden 505 Pulley & Clutch Removal Jaws	<b>91329</b>	FX-15 / FS-10 Internal Snap Ring Remover
		<b>91077</b>	Sanden 505 Shaft Protector Pilot		
		<b>91090</b>	Mitsubishi Seal Seat Remover		
		<b>91091</b>	Mitsubishi Seal Remover & Installer		
		<b>91104</b>	Ogura Retaining Nut Remover/Installer		
		<b>91105</b>	Ogura Seal Seat Remover/Installer		

**All tools available individually.**

## 91333 IMPORT COMPRESSOR SEAL & CLUTCH SERVICE TOOL SET

Contains all tools in set 91323 (IMPORT COMPRESSOR SEAL AND CLUTCH TOOL SET) and comes with 91183 air conditioning manual in a rugged metal flat tool box.



## 91340 UNIVERSAL SEAL & CLUTCH SERVICE TOOL SET

Contains all tools in sets 91323 (IMPORT COMPRESSOR SEAL AND CLUTCH TOOL SET), 91268 (MASTER SEAL SERVICE TOOL SET) and 91274 (MASTER CLUTCH SERVICE TOOL SET) and comes in a rugged metal three drawer tool box.



## 91141 DIESEL KIKI (ZEXEL) SEAL AND CLUTCH TOOL SET

Serves standard Diesel Kiki and York compressor models DKS 12 and DKS 15. Complete with tool box and instructions.

Contains:

<b>90383</b>	Internal Snap-Ring Pliers	<b>91058</b>	Pulley Removal Jaws
<b>90386</b>	Compressor Holding Fixture	<b>91074</b>	Bearing & Pulley Installer
<b>90390</b>	Pulley Bearing Driver	<b>91134</b>	Thrust Bolt Shim Gauge
<b>90396</b>	6" Clutch Bearing Installer	<b>91135</b>	Snap-Ring, O-Ring, Felt Installer
<b>90412</b>	O-Ring Seal Sleeve Remover	<b>91137</b>	Pulley Puller Pilot
<b>90414</b>	Seal Seat Remover	<b>91138</b>	Seal Remover & Installer
<b>90451</b>	Pulley Puller Arbor	<b>91139</b>	Seal Remover & Installer
<b>90457</b>	Universal Puller Body	<b>91146</b>	Universal Feeler Gauge Set
<b>90462</b>	Seal Seat Installer		<b>All tools available individually.</b>
<b>90499</b>	Universal Clutch Holding Tool		
<b>90903</b>	External Snap-ring Pliers		
<b>90906</b>	Seal Remover & Installer		
<b>90910</b>	Clutch Plate Installer		
<b>90923</b>	Internal Snap-Ring Pliers		
<b>91047</b>	Tool Box		
<b>91043</b>	Valve Plate Remover		
<b>91044</b>	Lock Nut Remover & Installer		
<b>91045</b>	Clutch Plate Remover		

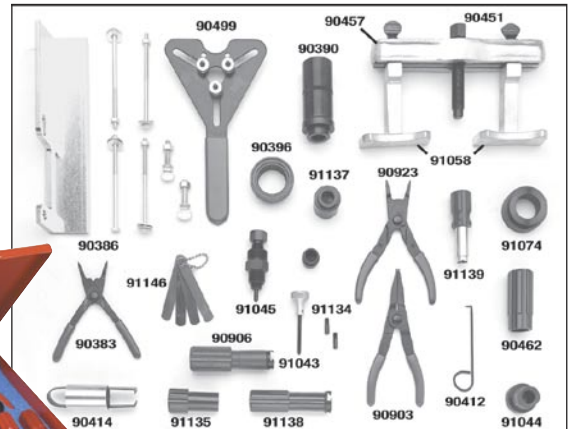



**91292 MASTER SANDEN COMPRESSOR SERVICE TOOL SET**

All specialized tools necessary to service seal, clutch and clutch bearing on Sanden 505, 507, 508, 510 and 575. Complete with tool box and instructions. Contains:

- |                                                  |                                                    |
|--------------------------------------------------|----------------------------------------------------|
| <b>90381</b> Holding Fixture & Hardware          | <b>90923</b> Internal Retaining Ring Plier         |
| <b>90383</b> Internal Snap Ring Plier            | <b>90926</b> Clutch Installing Pilot               |
| <b>90385</b> York Seal Remover/Installer         | <b>91047</b> Metal Tool Box                        |
| <b>90412</b> O-Ring Seal Sleeve Remover          | <b>91052</b> Clutch Plate Installer                |
| <b>90414</b> Seal Seat Remover                   | <b>91059</b> Bearing & Pulley Installer            |
| <b>90443</b> Pulley Bearing Remover/Driver       | <b>91073</b> Sanden 505 Seal Seat Remover          |
| <b>90451</b> Pulley Arbor                        | <b>91074</b> Sanden 505 Bearing & Pulley Installer |
| <b>90457</b> Puller Body                         | <b>91075</b> Sanden 505 Seal Protector Sleeve      |
| <b>90901</b> Clutch Holder                       | <b>91076</b> Pulley & Clutch Remover Jaws          |
| <b>90902</b> Clutch Plate Puller                 | <b>91077</b> Shaft Protector Pilot                 |
| <b>90903</b> External Retainer Remover/Installer | <b>91146</b> Feeler Gauge Set                      |
| <b>90905</b> Seal Retainer Remover/Installer     | <b>All tools available individually.</b>           |
| <b>90906</b> Seal Remover & Installer            |                                                    |
| <b>90907</b> Seal Protector Sleeve               |                                                    |
| <b>90910</b> Clutch Plate Installer              |                                                    |
| <b>90916</b> Oil Level Checker                   |                                                    |



**91295 MASTER IMPORT COMPRESSOR CLUTCH, SEAL & BEARING SERVICE TOOL SET**

Includes all the tools necessary to replace seals, clutches and clutch bearing on Diesel Kiki (Zexel), Hitachi, Mitsubishi, Nippondenso, Seiko-Seiki and Sanden 505, 507, 508, 510, 575, 708 and 709. Complete with tool box and instructions.

Contains:

- |                                                    |                                                        |
|----------------------------------------------------|--------------------------------------------------------|
| <b>90385</b> York Seal Remover & Installer         | <b>91091</b> Mitsubishi Seal Remover & Installer       |
| <b>90386</b> Compressor Holding Fixture            | <b>91134</b> Diesel Kiki Clutch Puller Thrust Pin      |
| <b>90390</b> Diesel Kiki Bearing Drive             | <b>91135</b> Diesel Kiki Retainer Ring Installer       |
| <b>90396</b> Diesel Kiki Clutch Installer          | <b>91136</b> Mitsubishi/Sanden Clutch Plate Remover    |
| <b>90443</b> Pulley Bearing Remover & Installer    | <b>91137</b> Diesel Kiki Pulley Puller Pilot           |
| <b>90451</b> Pulley Arbor                          | <b>91138</b> Diesel Kiki Seal Remover & Installer      |
| <b>90457</b> Puller Body                           | <b>91139</b> Diesel Kiki Seal Seat Remover & Installer |
| <b>90499</b> Universal Clutch Holding Tool         | <b>91146</b> Universal Feeler Gauge Set                |
| <b>90906</b> Seal Remover & Installer              | <b>91171</b> Mitsubishi Seal Remover Lock Sleeve       |
| <b>90907</b> Seal Protector Sleeve                 | <b>91183</b> Air Conditioning Manual                   |
| <b>90910</b> Clutch Plate Installer                | <b>91311</b> Hitachi Spanner Plug Remover & Installer  |
| <b>91011</b> Nippondenso Clutch Plate Remover      | <b>All tools available individually.</b>               |
| <b>91047</b> Metal Tool Box                        |                                                        |
| <b>91044</b> Diesel Kiki Nut Remover               |                                                        |
| <b>91045</b> Diesel Kiki Plate Remover             |                                                        |
| <b>91052</b> Sanden Plate Installer                |                                                        |
| <b>91058</b> Pulley Removal Jaws                   |                                                        |
| <b>91059</b> Bearing & Pulley Installer            |                                                        |
| <b>91060</b> Seal Seat Remover                     |                                                        |
| <b>91061</b> Seal Seat Installer                   |                                                        |
| <b>91073</b> Sanden 505 Seal Seat Remover          |                                                        |
| <b>91074</b> Sanden 505 Bearing & Pulley Installer |                                                        |
| <b>91075</b> Sanden 505 Seal Protector Sleeve      |                                                        |
| <b>91090</b> Mitsubishi Seal Seat Remover          |                                                        |





- 90499** Universal Clutch Holding Tool
- 91195** Clutch Plate Removal Arbor

## 91269 SEAL SERVICE KIT

General Motors A6, R4, Late DA6, HR-6, V5, 6 Pole R4 Seal Set Includes the tools needed to replace seals on GM compressors from the early sixties through the current model year as well as Tecumseh HR-980.

Contains:

- 90383** Internal Snap Ring Pliers
- 90412** O-Ring Seal Sleeve Remover
- 90414** Seal Seat Remover
- 90415** Seal Remover & Installer
- 90454** Clutch Plate Remover (Coarse Thread)
- 90458** Clutch Plate Installer (Coarse Thread)
- 90460** O-Ring Installation Guide
- 90462** Seal Seat Installer
- 90484** Seal Protector
- 90486** Ceramic Seal Installer



## 91270 SPECIAL GM DA6 SEAL SET

For carbon type seals used with tools from Set 91269. Contains:

- 91208** Seal Remover & Installer
- 91211** Shaft Protector
- 91212** Clutch Plate Remover (Metric Thread)
- 91213** Clutch Plate Installer (Metric Thread)
- 91214** O-Ring & Snap-Ring Installer
- 91215** O-Ring Installation Guide

All specialized tools needed when replacing seals on the above compressors. Used with tools from Set 91269. Contains:

- 91052** Clutch Plate Installer
- 91060** Seal Seat Remover
- 91061** Seal Seat Installer
- 91122** Clutch Plate Remover
- 91202** O-Ring Installation Guide

## 91002 GM & FORD ORIFICE TUBE REMOVER/INSTALLER

Used on all GM (CCOT) and Ford (FOTCC) systems with evaporator inlet orifice tube.



## 91008 FORD (FOTCC) REMOVER/INSTALLER

Used for Ford systems produced after 1980.



## 91009 GM (CCOT) & FORD (FOTCC) SCREEN EXTRACTOR

Used with 91002 and 91008



## 91010 FORD AEROSTAR EXPANSION TUBE REMOVER/INSTALLER

Special design for condenser mounted tube.

## 91273 SANDEN 507/508/510 SEAL SET

All specialized tools needed when replacing seals on Sanden Model 507, 508 and 510 compressors. Used with tools from Set 91269. Contains:

- 90902** Clutch End Plate Puller
- 90906** Seal Remover & Installer
- 90907** Seal Protector Sleeve
- 90910** Clutch Face Plate Installer



POPULAR

### 91000-A DELUXE CLUTCH HUB PULLER/INSTALLER KIT

Kit contains a complete offering of A/C compressor clutch hub pullers and installers for GM, Ford, Chrysler and Imports. Includes a compressor identification chart and comes in a custom molded case.

### 90499 UNIVERSAL CLUTCH HOLDING TOOL

### 92329 TOYOTA A/C DISCONNECT TOOL

The new Toyota spring lock A/C hose couplings require this special disconnect tool. Simply insert the end of the tool into the coupling to disengage the hose.

### 91320 NIPPONDENSO 10 PA17 SEAL SET

Includes all tools necessary to replace seals on Nippondenso. Used with tools from Set 91269. Contains:

- 91317** Shaft Seal Remover
- 91318** Shaft Seal Installer
- 91319** Shaft Protector
- 91329** Internal Snap-Ring Remover
- 91352** Plastic Box

### 92311 DELUXE ORIFICE TUBE SERVICE KIT













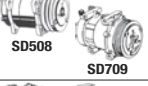
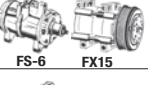

This 5 piece universal kit will remove and install any style orifice tube. Comes in custom molded box.

### 91332 FORD FX-15/FS-10 SERVICE SEAL SET

Includes all special tools needed to replace the seals on FX-15/FS-10 compressor. Contains:

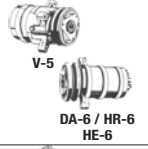

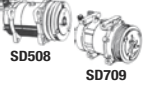

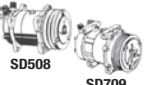





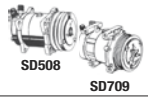

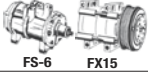

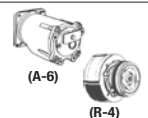





- 91326** Shaft Seal Remover
- 91327** Shaft Seal Installer
- 91328** Shaft Protector (16 Spline)
- 91329** Internal Snap-Ring Remover
- 91352** Plastic Box

# COMPRESSOR TOOL CHART

VEHICLE	COMPRESSOR MFG.	COMPRESSOR MODEL NUMBER	CLUTCH HUB		CLUTCH PULLEY		CLUTCH COIL		SHAFT SEAL		CLUTCH BEARING		Image
			Remover	Installer	Remover	Installer	Remover	Installer	Remover	Installer	Remover	Installer	
Acura / Honda	Nippondenso	6P Series 69127 10913 / 15	91011	91052	90450 91012	91059			91060 90499	91061	91059 91065	91059	 10P15
Audi	Delphi / Harrison	Harrison / GM A-6	90454	90458	90450 90455	91059			90414 90415 90499 90462	90414 90415 90486 90486	90350 90460 90412	90349	 (A-6)
	Zexel (Diesel Kiki)	DGW	91045		90917 90450	90910			91138 90499	91138	90443	91059	 Diesel Kiki
Audi / VW	Nippondenso	10PA-17 / 10P15	91011	91052	90450 91012	91059			91319 91317	91318 91319	91059 91065	91059	 10P15 10P17
	Sanden	TRS90 / 105	90902	90910	90926 90917	91059			90914	90414 90415	90443 90906	91059	 SD508
SD507 / 508 / 510 / 708 709 / 7H15 Lip Seal		90902	90910	90450	91059			90412	90908				
BMW	Nippondenso	10PA-17 / 10P15	91011	91052	90450 91012	91059			91319 91317	91318 91319	91059 91065	91059	 10P15 10P17
Chrysler / Dodge	Nippondenso	6C17	91303 91304		90450 91012	91059			91302 91302	91301 91065	91059	91059	
	Sanden	Sanden TRS90 / 105	90902	90910	90902 90917	91059			90914 90415	90414 90906	90443	91059	 SD508 SD709
SD507 / 508 / 510 / 708 709 / 7H15 Lip Seal		90902	90910	90450	91059			90412	90908	90443	91059		
Ford / Lincoln	Ford	FS-6	91122	91052	91012	91059	90450	91331	90499		91327	91065	 FS-6 FX15
		FS-10 (R134a) / FX-15	91122	91052	90450 91012	91059	91330	91331	91326 91328		91327	91065	
	Nippondenso	6P148	91011	91052	90450 91012	91059			91060 90499	91061	91059 91065	91059	 10P15
10PA-17 / 10P15		91011	91052	90450 91012	91059			91319 91317	91318 91319	91059 91065	91059		
General Motors	Delphi / Harrison	Harrison / GM A-6	90454	90458	90450 90455	91059			90414 90415 90486 90499 90462	90414 90415 90486 90486	90460	90349	 (A-6)
		R-4 Concave Shaft Tip	90454	90458	90346	90349	90346 90450	90292	90414 90415	90414 90415			 R-4
		Pointed Shaft Tip	91196	90458	90347	90349	90910	90292	90412 90499	90460 90484			
		V-5 & V-7 DA6 HR6 / HR6HE	91212	91213	90450 90453	91059	90450 90455 90291	90292	90486 91208 90412 90499 91170 90499	90486 91208 91214 90183 91211 91270	90350	90349	 V-5 DA-6 / HR-6 HE-6
Honda	Sanden	10PA-17 / 10P15	91011	91052	90450 91012	91059			91319 91317	91318 91319	91059 91065	91059	 10P15
Hyundai	Zexel (Diesel Kiki)	DKS15-BH			90450				90499				
	Sanden	Sanden TRS90 / 105	90902	90910	90926 90917	91059			90414 90415	90414 90906	90443	91059	 SD508 SD709
		SD507 / 508 / 510 / 708 709 / 7H15 Lip Seal	90902	90910	90450	91059			90412	90908	90443	91059	
Isuzu	Delphi / Harrison	R-4 Concave	90454	90458	90346	90349	90346 90450	90292	90414 90415	90414 90415	90350	90349	 R-4
		Pointed Shaft Tip	91196	90458	90347	90349	90910	90292	90412 90499	90460 90484	90350	90349	
	Zexel (Diesel Kiki)	DKS 13/14/17 DGW / DKS15-BH			90450				90499				 Diesel Kiki
Jaguar	Sanden	SD5 & 7 Series Sanden TRS90 / 105	90902	90910	90926	91059			90914 90906	90414	90443	91059	 SD508 SD709
		SD507 / 508 / 510 / 708 709 / 7H15 Lip Seal	90902	90910	90917 90450	91059			90415 90412	90908	90443	91059	



# COMPRESSOR TOOL CHART

VEHICLE	COMPRESSOR MFG.	COMPRESSOR MODEL NUMBER	CLUTCH HUB		CLUTCH PULLEY		CLUTCH COIL		SHAFT SEAL		CLUTCH BEARING		
			Remover	Installer	Remover	Installer	Remover	Installer	Remover	Installer	Remover	Installer	
Jeep / Chrysler	Sanden	SD5 & 7 Series Sanden TRS90 / 105	90902	90910	90926	91059			90914	90414 90906	90443	91059	
		SD507 / 508 / 510 / 708 709 / 7H15 Lip Seal	90902	90910	90917 90450	91059			90415 90412	90908	90443	91059	
Mazda	Nippondenso	10PA-17 / 10P15	91011	91052	90450 91012	91059			91319 91317	91318 91319	91059 91065	91059	
	Ford	FS-6 FS-10 (R134a) / FX-15	91122	91052	91012		90450 91012	91059 90450 91331	90499 91326 91328	91327	91065		
	Sanden	SD5 & SD7 Sanden TRS90 / 105	90902	90910	90926	91059			90914	90414 90906	90443	91059	
		SD507 / 508 / 510 / 708 709 / 7H15 Lip Seal	90902	90910	90917 90450	91059			90415 90412	90908	90443	91059	
Mercedes Benz	Delphi / Harrison	A-6 & R-4	90454	90458	90450 90455	91059			90414 90415 90486 90499	90414 90415 90412 90486 90462	90460	90349	
	Nippondenso	10P15 / 1710PA-17	91011	91052	90450 91012	91059			91319 91317	91318 91319	91059 91065	91059	
Mitsubishi	Mitsubishi	CH Series FX105	92260 90902		90917 90450	90910			91338 90499	91138	90443	91059	
	Nippondenso	10P15-17 / 10PA-17	91011	91052	90450 91012	91059			91319 91317	91318 91319	91059 91065	91059	
Nissan / Infiniti	Zexel (Diesel Kiki)	DKV-14C CH Series	92260 90902		90917 90450	90910			91328 90499	91138	90443	91059	
		DKS-16H CH Series	92260 90902		90917 90450	90910			91328 90499	91138	90443	91059	
Nissan	Ford	FS-10 FS-6 FS-10 (R134a) FX-15	91122	91052	91012 90450	91059	90450 91330	91331	90499 91328	91327	91065		
	Hitachi	MJS170 6P Series	91011	91052	90450 91012	91059			91060 90499	91061	91059 91065	91059	
Porsche	Nippondenso	10P 10PA-17 10P15	91011	91052	90450 91012	91059			91319 91317	91318 91319	91059 91065	91059	
	Hitachi	10P	91011	91052	90450 91012	91059			91060 90499	91061	91059 91065	91059	
	Sanden	SD5 Sanden TR594105 SD507 / 508 / 510 / 708 709 / 7H15 Lip Seal	90902	90910	90926 90917 90450	91059			90914 90415 90412	90414 90908	90443	91059	
Saab	*Sanden Seiko Seiki	SD5 Series / SS170 Sanden TR59105	90902	90910	90926	91059			90914	90414 90906	90443	91059	
		SD507 / 508 / 510 / 708 709 / 7H15 Lip Seal	90902	90910	90917 90450	91059			90415 90412	90908	90443	91059	
Saturn	Zexel (Diesel Kiki)	DKV CH Series	92260 90902		90917 90450	90910			91328 90499	91138	90443	91059	
Subaru	Zexel (Diesel Kiki)	*92 Model / 93 CH Series	92260 90902		90917 90450	90910			91328 90499	91138	90443	91059	
Suzuki	Nippondenso	10P8 10PA-17 10P15	91011	91052	90450 91012	91059			91319 91317	91318 91319	91059 91065	91059	
Toyota / Lexus	Nippondenso	10P13 / 15 / 17 10PA-17 10P15	91011	91052	90450 91012	91059			91319 91317	91318 91319	91059 91065	91059	
MB/Porsche/VW	York	206 / 209 / 210 York / Tecumseh	90440								90443	91059	
Volvo	Zexel (Diesel Kiki)	DKS-15 CH Series	92260 90902		90917 90450	90910			91328 90499	91138	90443	91059	
	Sanden	SD508 / 510 / 709 Sanden TR594105 SD507 / 508 / 510 / 708 709 / 7H15 Lip Seal	90902	90910	90926 90917 90450	91059			90914 90415 90412	90414 90908	90443	91059	
Volvo / Jaguar	Delphi / Harrison	A-6 & R-4 CH Series	90454	90458	90450 90455	91059			90414 90415 90486 90499	90414 90415 90412 90486 90462	90460	90349	

ITEM #	PAGE	ITEM #	PAGE	ITEM #	PAGE	ITEM #	PAGE	ITEM #	PAGE	ITEM #	PAGE		
0377-001	13	41723	10	47724	10	53450-C	26	70027	37	71206	35, 36	80234	12
0378-001	13	41961	10	47961	10	53500	27	70028	37	71214	35, 36	80296	14
0531-001	13	41962	10	47962	10	53500-C	27	70029	37	71215	35, 36	80636	8
0768-001	13	41963	10	47963	10	53515	28	70030	38	71216	35, 36	80661	8
0769-001	13	42010	10	47964	10	53515-B	28, 30, 31	70031	38	71300	36	80772	8
1336-006	13	42010-10	11	48364	10	53580	27	70033	36, 37	71400	35	81113	8
1336-008	13	42014	13	48604	10	53585	27	70034	37	71405	35	81174	15
1336-010	13	42014-10	11	48724	10	53609	29	70035	37	71406	35	81290	13, 16
1336-012	13	45336	10	48964	10	53610	29	70037	37	71415	35	81297	14, 15
1336-016	13	45360	10	49236-36	10	53625	29	70038	37	71416	35	81359	15
1336-018	13	45361	10	49262-36	10	53809	29	70051	36	71450	35	81379	14, 15
1336-110	13	45362	10	49262-60	10	53810	29	70069-A	38	71450-PB	35	82010	13
1336-112	13	45363	10	49262-72	10	53825	29	70071	38	71475	35	82010-10	11
32136	8	45372	10	49263-60	10	53826	29	70072	38	71475-10M	35	82031	18
32161	8	45396	10	49263-72	10	53827	29	70073	38	71475-110M	35	82214	12
32172	8	45601	10	49264-36	10	55100	30	70074	38	71475-14M	35	82214-E	12
32636	8	45602	10	49264-60	10	55100-SEN	30	70075	38	71475-16M	35	82224	12
32661	8	45603	10	49264-72	10	55200	30	70076	38	71475-18M	35	82224-E	12
32772	8	45721	10	49265-36	10	55300	30	70077	38	71475-4M	35	82272	14
33103	8	45722	10	49265-60	10	55310	30	70081	38	71475-6M	35	82274	14, 15
33113	8	45723	10	49265-72	10	55400	30	70082	38	71475-8M	35	82275	14, 15
33136	8	45961	10	52161	33	55500	31	70085	38	71475-PB	35	82332	14, 15
33161	8	45962	10	52220	33	55500-220	31	70092	36	71480	36	82333	14, 15
33172	8	45963	10	52223-A	33	55500-SEN	31	70092-M	36	71500	34	82335	14
33636	8	46336	10	52224-A	32	55750	31	70097	36	71500-001A	34	82336	13
33661	8	46360	10	52224-C	32	55750-220	31	70097-M	36	71500-001B	34	82336-10	11
33772	8	46361	10	52225-A	32	58490	16	70128	37	71500-001C	34	82354	14, 15
34215	8	46362	10	52225-B	33	58531	16	70134	37	71500-10	34	82357	14, 15
34216	8	46363	10	52226	33	58560	16	70138	37	71500-10SRB	34	82358	14, 15
35136	8	46364	10	52227	33	60034-10	12	70192	36	71500-12	34	82374	29
35161	8	46372	10	52331	33	60134-10	12	70192-M	36	71500-12SRB	34	82375	29
35172	8	46396	10	52332	33	62010	17	70233	37	71500-6	34	82495	11
35636	8	46601	10	52333	33	62011	17	70237	37	71500-6SRB	34	82633	14
35661	8	46602	10	52334	33	62012	17	70238	37	71500-8	34	82634	12, 14
35772	8	46603	10	52335	33	63010	17	71097-01	35, 36	71500-PB	34	82634-M	12, 14
36136	8	46604	10	53012	28	63010-AUS	17	71097-03	35, 36	71550	34	82635	12
36161	8	46721	10	53012-B	28	64010	17	71097-04	35, 36	71550-001	34	82733	12
36172	8	46722	10	53012-L	28	65010	17	71097-05	35, 36	71550-002	34	82734	12, 14
36636	8	46723	10	53100	26	66010	17	71097-06	35, 36	71550-003	34	82735	12
36661	8	46724	10	53100-C	26	66011	17	71097-08	35, 36	71685	38	82736	12
36772	8	46961	10	53110-L	28	66012	17	71097-13	35, 36	71686-2	38	82738	12
37136	8	46962	10	53112	28	66434-R	12	71097-14	35, 36	72029	37	82834	12
37161	8	46963	10	53123	29	66534-R	12	71097-15	35, 36	72030	37	82834-E	12
37172	8	46964	10	53123-A	29	66660	8	71097-16	35, 36	72034	37	82934	12
37636	8	47336	10	53134	29	66661	8	71097-18	35, 36	72035	37	82934-E	12
37661	8	47360	10	53223	29	67010	17	71098	36	80011	15	83136	8
37772	8	47361	10	53312	28	67011	17	71098-01	36	80013	15	83161	8
40336	10	47362	10	53312-B	28	69000	22	71098-03	36	80021	38	83172	8
40360	10	47363	10	53312-L	28	69000-220	22	71098-13	36	80034	12, 13	83341	12, 13
40372	10	47364	10	53314	28	69100	22	71098-14	36	80034-1	13	83341-10	11
40396	10	47372	10	53414-220	28	69110	22	71098-15	36	80103	8	83436	8
41361	10	47396	10	53315	28	69300	23	71098-16	36	80111	15	83461	8
41362	10	47601	10	53322	29	69300-220	23	71098-18	36	80113	15	83472	8
41363	10	47602	10	53351	27	69360-220	23	71100	36	80121	38	84136	8
41601	10	47603	10	53411	28	69360	23	71101	36	80134	12, 13	84161	8
41602	10	47604	10	53412	28	69500	24	71200-PB	35	80134-1	13	84172	8
41603	10	47721	10	53413	28	69788	25	71201	35, 36	80136	8	84336	10
41721	10	47722	10	53414	28	69788-FL-TRPK	25	71204	35, 36	80161	8	84360	10
41722	10	47723	10	53450	26			71205	35, 36	80172	8	84361	10



ITEM #	PAGE	ITEM #	PAGE	ITEM #	PAGE	ITEM #	PAGE	ITEM #	PAGE	ITEM #	PAGE	ITEM #	PAGE
84362	10	89636	7	90347	43	90906	39, 40, 41, 42, 43, 44	91146	39, 40, 41	91503-E	6, 9	95272	6
84363	10	89660	7	90349	39, 43, 44	90907	39, 41, 42	91170	43	91553-E	6, 9	95336	6
84364	10	89661	7	90350	43	90908	43, 44	91171	40, 41	91580	24	95361	6
84365	10	89772	7	90354	14	90910	39, 40, 41, 42, 43, 44	91183	39, 41	91580-A	24	95372	6
84372	10	90010-6	19	90355	14	90914	43, 44	91190	40	91580-B	24	95436	6
84396	10	90018-6	19	90356	14	90916	40, 41	91195	39, 42	91581	24	95461	6
84601	10	90024-6	19	90357	14	90917	40, 43, 44	91196	43	91585	24	95472	6
84602	10	90032-6	19	90358	14	90922	40	91200	18	91585-B	24	95536	7
84603	10	90059-R	19	90363	12	90923	40, 41	91202	39, 42	91586	24	95561	7
84604	10	90060	18	90364	12	90924	14	91207	13	91587	24	95572	7
84605	10	90062-A	19	90365	11	90925	15	91208	39, 42, 43	91588	24	95636	7
84636	8	90065	18	90368	13	90926	40, 41, 43, 44	91211	39, 42, 43	91680	24	95661	7
84661	8	90066-2V-110	19	90369	13	90927	14	91212	39, 42, 43	91681	24	95772	7
84721	10	90066-A	19	90373	14	91000-A	42	91213	39, 42, 43	91685	24	96136	7
84722	10	90067	18	90375	29	91002	42	91214	39, 42, 43	91686	24	96161	7
84723	10	90070-2V-110	19	90376	16	91008	42	91215	39, 42	91687	24	96172	7
84724	10	90128-4	19	90377	16	91009	42	91216	39	91688	24	96636	7
84725	10	90160-R	18	90378	13	91010	42	91218	39	92107	13	96661	7
84772	8	90165-R	18	90381	41	91011	41, 43, 44	91250	6, 8, 9	92136	7	96772	7
84961	10	90167-R	18	90383	39, 40, 41, 42	91012	39, 43, 44	91253-E	6, 9	92161	7	97136	7
84962	10	90183	43	90385	40, 41	91022	39	91261	39	92172	7	97161	7
84963	10	90259	11	90386	40, 41	91023	39	91267	39	92210	39	97172	7
84964	10	90262	11	90389	11	91043	40	91268	39	92260	44	97636	7
84965	10	90262-36	10	90390	40, 41	91044	40, 41	91269	42	92311	42	97661	7
85103	7	90262-60	10	90396	40, 41	91045	40, 41, 43	91270	42, 43	92329	42	97772	7
85113	7	90262-72	10	90410	14	91046-A	16	91271	42	92376	29	98061	19
85136	7	90263	11	90412	39, 40, 41, 42, 43, 44	91047	39, 40, 41	91273	42	92398	28	98061-C	19
85161	7	90263-36	10	90414	39, 40, 41, 42, 43, 44	91048	16	91274	39	92636	7	98061-SENSOR	19
85172	7	90263-60	10	90415	39, 42, 43, 44	91052	39, 41, 42, 43, 44	91289	40	92661	7	98100	21
85200	13	90263-72	10	90430	11	91058	39, 40, 41	91290	13, 15, 16	92699	29	98210-A	20
85215	7	90264	11	90431	39	91059	39, 41, 43, 44	91292	41	92708	29	98211-A	20
85216	7	90264-36	10	90432	39	91060	39, 41, 42, 43, 44	91295	41	92709	29	98230	20
85253-E	9	90264-60	10	90440	39, 44	91061	39, 41, 42, 43, 44	91301	43	92710	29	98250	21
85350	8, 9	90264-72	10	90441	39	91065	43, 44	91302	43	92711	29	98250-220	21
85500	8, 9	90265	11	90443	39, 41, 43, 44	91073	40, 41	91303	43	92712	29	98251-E	6, 9
85510	15	90265-36	10	90444	39	91074	40, 41	91304	43	92732	29	98300	21
85530	15	90265-60	10	90445	39, 43, 44	91075	40, 41	91311	41	92772	7	98300-220	21
85636	7	90265-72	10	90450	39, 40, 41	91076	40, 41	91316	40	93000	15	98364	10
85661	7	90269	11	90451	39, 40, 41	91077	40, 41	91317	42, 43, 44	93098	15	98370	12
85772	7	90274	14	90452	39	91084	14	91318	42, 43, 44	93099	15	98604	10
86103	6	90279	11	90453	43	91090	40, 41	91319	42, 43, 44	93100	15	98660	7
86350	6, 8, 9	90289	11	90454	39, 42, 43, 44	91091	40, 41	91320	42	93101	15	98661	7
86436	6	90291	39, 43	90455	39, 43, 44	91097-05	36	91323	40	93103	7	98724	10
86461	6	90292	39, 43	90456	39	91097-06	36	91326	40, 42, 43, 44	93113	7	98964	10
86472	6	90296	14	90457	39, 40, 41	91097-08	36	91327	40, 42, 43, 44	93136	7	99134-A	5
86500	6, 8, 9	90311	40	90458	39, 42, 43, 44	91104	40	91328	40, 42, 43, 44	93161	7	99134-A-UPDT-10	5
86536	6	90312	40	90460	39, 42, 43, 44	91105	40	91329	40, 42	93172	7	99333	19
86561	6	90314	14	90462	39, 40, 42, 43, 44	91106	40	91330	43, 44	93253-E	9	99334-110	19
86572	6	90328	12	90473	39	91120	33	91331	43, 44	93350	8, 9	99334-220	19
86936	6	90332	14	90474	39	91122	39, 42, 43, 44	91332	42	93500	8, 9	99860-A	5
86961	6	90333-R	11, 14	90484	39, 42, 43	91134	40, 41	91333	40	93503-E	9	99872-A	5
86972	6	90333-UV	11	90486	39, 42, 43, 44	91135	40, 41	91334	13	93553-E	9	MC98RG	15
88136	7	90335-R	11, 14	90499	39, 40, 41, 42, 43, 44	91136	40, 41	91335	13	93636	7		
88161	7	90336	13	90633	14	91137	40, 41	91336	13	93772	7		
88172	7	90336-10	11	90637	14	91138	40, 41, 43, 44	91337	13	95103	6		
88436	7	90337	11, 14	90901	40, 41	91139	40, 41	91338	15, 44	95136	6		
88461	7	90338	14	90902	39, 41, 42, 43, 44	91141	40	91340	40	95161	6		
88472	7	90340	14	90905	40, 41			91352	42	95172	6		
89136	7	90341	13					91390	15	95236	6		
89161	7	90343	39					91490	16	95261	6		
89172	7	90346	39, 43					91500	6, 8, 9				





**Mastercool**<sup>®</sup> Inc.

*"World Class Quality"*

One Aspen Drive Randolph, NJ 07869 USA  
Phone: (973) 252-9119 / Fax: (973) 252-2455

Europark Noord 14B  
9100 Sint Niklaas, Belgium  
Telefon: +32 (0) 3 777 28 48 / Telefax: +32 (0) 3 777 40 62

website: [www.mastercool.com](http://www.mastercool.com) / email: [customerservice@mastercool.com](mailto:customerservice@mastercool.com)