

# Electronic Expansion Valve

## Series LPF

LPF series Electronic Expansion Valves are especially designed for use in refrigeration systems. Thanks to the soft-sealing seat design, it can be as tight as a solenoid valve once it is completely shut off thus to prevent liquid refrigerant migrate to evaporator or compressor.



### Features

- Extremely high internal tightness, which is as good as with solenoid valves(<1ml/min)
- Equal percentage flow design for better flow regulation
- Snap-on coil for easier installation
- Coil with IP67 works safely in extremely environment
- Applicable for oil-free system
- Built-in strainer at inlet
- Flow direction: Uni-flow
- LPF...D : 60 bar design for R744 refrigerant

### General Specification

- Applicable for all common HFCF, HFC and HFO refrigerants such as R134a, R404A, R407A/F, R407C, R410A, R448A, R449A, R450A, R452A, R513A, R507A and also for flammable refrigerants like R290, R1234ze, R454C, R455A, R1234yf and R744 (Co2)
- 500 steps (full stroke); 32 ± 20 opening steps
- Medium temperature TS min./max.: -40°C / +70°C (duty cycle rate below 40%)
- Ambient temperature min./max.: -40°C / +60°C (duty cycle rate below 40%)
- Relative humidity: 0 to 95% RH
- Design Pressure: 42 bar, MOPD: 35 bar (LPF series)  
60 bar, MOPD: 35 bar (LPF...D series, designed for R744 refrigerant)
- Reverse operating pressure difference ≥ 21 bar

## Electrical Parameters

- Rated voltage : 12V DC ( $\pm 10\%$ ), rectangular wave
- Excitation mode : 1 - 2 phase excitation, uni-polar actuation
- Excitation rate : 30 - 90pps
- Full stroke time : 6s @ 90pps
- Coil current : 260 mA/phase (20°C)
- Coil resistance :  $46 \pm 3.7 \Omega$ /phase (20°C)
- Insulation class of coil : E
- Protection class : IP 67
- Compatible with Sanhua controller SEC series

**Selection**

**Condition 1:** Tc/Te/Sc/SH: 45°C/-10°C/2K/6K (0°C/-20°C/2K/6K for R744)

Valve Model	Seat $\phi$ [mm]	Kv [m <sup>3</sup> /h]	Maximal Cooling Capacity [kW]							
			R134a	R404A	R407F	R448A	R449A	R450A	R452A	R513A
LPF08	0.8	0.025	2.23	1.96	3.15	2.82	2.76	1.94	2.07	1.84
LPF08D										
LPF10	1.0	0.04	3.64	3.2	5.14	4.60	4.49	3.16	3.37	3.00
LPF10D										
LPF14	1.4	0.08	6.90	6.08	9.75	8.70	8.51	6.00	6.39	5.69
LPF14D										
LPF18	1.8	0.12	9.53	8.40	13.47	12.0	11.76	8.29	8.83	7.86
LPF18D										
LPF24	2.4	0.2	13.04	11.50	18.43	16.45	16.09	11.34	12.1	10.75
LPF24D										
LPF30	3.0	0.27	19.0	17	26.9	24.1	23.6	16.5	17.8	15.7
LPF32	3.2	0.30	20.8	18.7	19.6	26.4	25.9	18.1	19.6	17.2

Valve Model	Seat $\phi$ [mm]	Kv [m <sup>3</sup> /h]	Maximal Cooling Capacity [kW]							
			R454B	R454C	R455A	R1234yf	R1234ze	R290	R410A	R744
LPF08	0.8	0.025	4.0	2.41	2.62	1.57	1.72	3.0	3.43	4.7
LPF08D										
LPF10	1.0	0.04	6.52	3.93	4.27	2.55	2.81	4.87	5.6	7.6
LPF10D										
LPF14	1.4	0.08	12.36	7.45	8.10	4.84	5.32	9.23	10.6	14.4
LPF14D										
LPF18	1.8	0.12	17.08	10.3	11.20	6.69	7.36	12.7	14.64	19.9
LPF18D										
LPF24	2.4	0.2	23.37	14.1	15.32	9.16	10.07	17.3	20.0	27.2
LPF24D										
LPF30	3.0	0.27	34.2	20.6	22.5	13.4	14.6	25.4	29.5	-
LPF32	3.2	0.30	37.5	22.6	24.7	14.7	16.0	27.9	32.3	-

**Condition 2** : Tc/Te/Sc/SH: 45°C/-35°C/2K/6K (-10°C/-40°C/2K/6K for R744)

Valve Model	Seat $\phi$ [mm]	Kv [m <sup>3</sup> /h]	Maximal Cooling Capacity [kW]							
			R134a	R404A	R407F	R448A	R449A	R450A	R452A	R513A
LPF08	0.8	0.025	2.1	1.81	3.04	2.68	2.62	1.79	1.88	1.69
LPF08D										
LPF10	1.0	0.04	3.43	2.95	4.96	4.36	4.26	2.92	3.07	2.75
LPF10D										
LPF14	1.4	0.08	6.5	5.6	9.4	8.27	8.08	5.53	5.82	5.21
LPF14D										
LPF18	1.8	0.12	9.00	7.73	13.0	11.43	11.17	7.64	8.04	7.21
LPF18D										
LPF24	2.4	0.2	12.3	10.58	17.78	15.65	15.29	10.45	11.0	9.86
LPF24D										
LPF30	3.0	0.27	18.0	15.8	26.1	23.0	22.5	15.3	16.4	14.5
LPF32	3.2	0.30	19.7	17.4	28.7	25.3	24.7	16.8	18.0	15.9

Valve Model	Seat $\phi$ [mm]	Kv [m <sup>3</sup> /h]	Maximal Cooling Capacity [kW]							
			R454B	R454C	R455A	R1234yf	R1234ze	R290	R410A	R744
LPF08	0.8	0.025	4.03	2.23	2.43	1.4	1.57	2.86	3.42	5.4
LPF08D										
LPF10	1.0	0.04	6.56	3.63	3.95	2.28	2.55	4.66	5.57	8.8
LPF10D										
LPF14	1.4	0.08	12.45	6.89	7.50	4.33	4.84	8.84	10.57	16.6
LPF14D										
LPF18	1.8	0.12	17.20	9.53	10.36	5.98	6.69	12.21	14.61	23.0
LPF18D										
LPF24	2.4	0.2	23.54	13.03	14.17	8.18	9.15	16.7	20.0	31.5
LPF24D										
LPF30	3.0	0.27	34.6	19.2	20.9	12.0	13.4	24.4	28.3	-
LPF32	3.2	0.30	37.9	21.1	23.0	13.2	14.7	26.8	31	-

**Note** : The Max capacity is given for full opened position  
 LPF... is standard series, LPF...D is designed for Co2 application

**Flow Characteristic (Equal Percentage)**

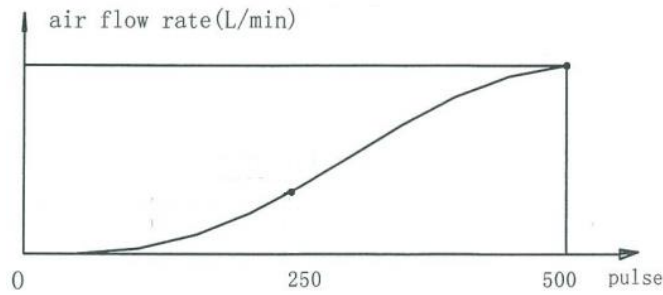

**Dimensions**

(Unit is mm)

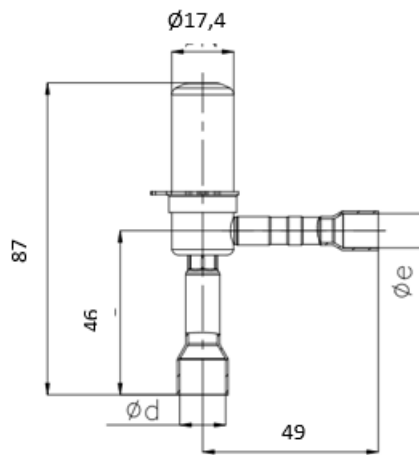

Valve Model	Code number Multi-Pack	Dimensions		Weight (g)
		$\text{Ø}e$ inlet	$\text{Ø}d$ outlet	
LPF08-001/ LPF08D-001	10136003202/ 10136003702	3/8	1/2	51,2
LPF08-002/ LPF08D-002	10136003302/ 10136003802	1/4	1/4	
LPF10-002/ LPF10D-002	10136000502/ 10136002002	3/8	1/2	
LPF10-003/ LPF10D-003	10136000602/ 10136002102	1/4	3/8	
LPF10-004/ LPF10D-004	10136000702/ 10136002202	10mm	12mm	
LPF10-005/ LPF10D-005	10136000802/ 10136002302	6mm	10mm	
LPF14-002/ LPF14D-002	10136000902/ 10136002402	3/8	1/2	
LPF14-003/ LPF14D-003	10136001002/ 10136002502	1/4	3/8	
LPF14-004/ LPF14D-004	10136001102/ 10136002602	10mm	12mm	
LPF14-005/ LPF14D-005	10136001202/ 10136002702	6mm	10mm	
LPF18-002/ LPF18D-002	10136001302/ 10136002802	3/8	1/2	
LPF18-003/ LPF18D-003	10136001402/ 10136002902	10mm	12mm	
LPF24-002/ LPF24D-002	10136001502/ 10136003002	3/8	1/2	
LPF24-003/ LPF24D-003	10136001602/ 10136003102	10mm	12mm	
LPF30-001	10136003902	3/8	1/2	
LPF32-001	10136003402	3/8	1/2	
LPF32-002	10136004002	1/4	3/8	

The coil is separated  
(Unit is mm)

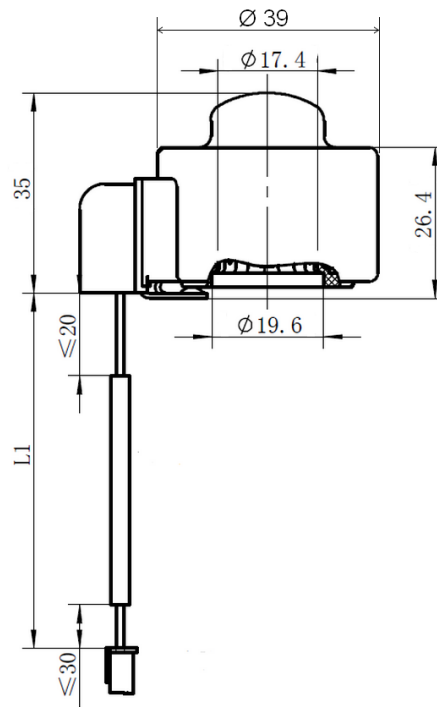

Coil Model	Coil Code number	Coil Dimensions [mm]	Weight (g)
		L1	
PQ-M24012-000007	10810127602	1500	140,2
PQ-M24012-000008	10810129502	3000	
PQ-M24012-000009	10810129602	6000	
PQ-M24012-000010	10810129702	9000	